

SPECIFICATIONS

Accuracy $\pm 5\%$

S.I. MODEL		TW750N2	TW1000N2
TORQUE RANGE [N · m]	MIN. - MAX.	350~750	400~1000
	GRAD.	5	
DIMENSION [mm]	SQ. DRIVE	25.4	
WEIGHT [kg]	BODY	20	
	TORQUE WRENCH	1.5	2

Notes

Interchangeable sockets, pins and O-rings (to prevent dropout) are not supplied.

Permissible height of nut position: approx. 250 to 800 mm above ground.

Standard accessories

Calibration certificate, manual, checklist.

DIMENSIONS

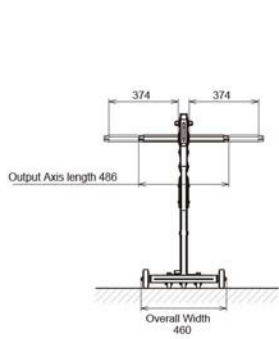

TW750N2, TW1000N2

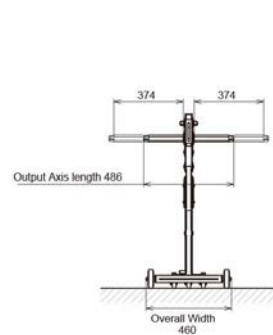
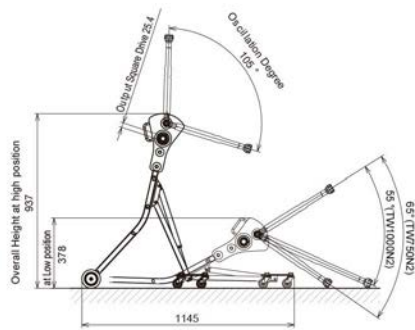

Available bolt position

