

DIGITAL LINE CHECKER MODEL LC2-G

PATENTED

OPERATING INSTRUCTION

LC20N2-G, LC200N2-G **LC20N2-G, LC200N2-G Models**



LC1000N2-G **LC1000N2-G Model**

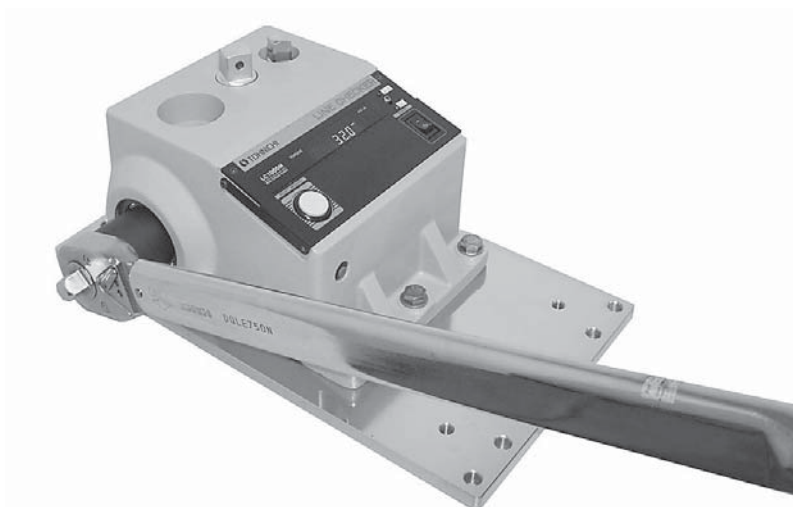

To use this product properly and safely, please read this manual carefully before use. If you have any question about the product and its operations, please contact your nearest distributor or TOHNICHI MFG. CO., LTD.

Safety Precautions

To customers: Before using this product, please read this operating instruction carefully to use it properly.

If you have any question, please contact your nearest distributor or TOHNICHI MFG. CO., LTD. This operating instruction should be stored in a safe place.





Safety Symbol

This symbol is used for drawing attention to "safety precautions". If you see this symbol in this operating instruction, attention should be paid to safety. Take preventative actions according to the description and conduct "safe operations and proper control".

Signal Words

The signal words are the headers which indicate the level of hazard that should be known for human safety and in handling devices. The signal words for safety are "Danger", "Warning" and "Caution" depending on the level of hazard to human. The signal words are used with the safety symbol to indicate the following situations.

" **Danger**": Indicates an imminently hazardous situation which, if not avoided, will result in death or serious injury.

" **Warning**": Indicates a potentially hazardous situation which, if not avoided, could result in death or serious injury.

" **Caution**": Indicates a potentially hazardous situation which, if not avoided, may result in minor or moderate injury.

Warning

(1) Stop using the product when smoke comes out or strange smell or unusual noise occurs.

Use in an abnormal state may result in electric shock or fire.

Immediately turn off the power, remove the plug from the outlet and contact your nearest distributor or TOHNICHI MFG. CO., LTD.

(2) Do not disassemble or modify this line checker.

It may result in loss of safety, degradation in functions, shortening of product life, or failure.

(3) Stop using the product when foreign matter or liquid such as water gets inside.

If not, you may be exposed to the danger of electric shock or fire.

(4) Do not connect or disconnect the power plug with wet hands. You may be exposed to the danger of electric shock.

(5) Do not use this line checker with a power voltage other than that specified (AC100V to 240V).

Use with any unspecified power voltage may result in electric shock or fire.

(6) Do not use a damaged power cable.

Use of a damaged power cable may result in electric shock or fire.

When handling the power cable, follow the instructions below.

- Do not damage, extend or heat the power cable.

- Do not yank the power cable, put heavy objects on it, or pinch it.

- Do not bend the power cable by force, twist it or bind it.

- Do not use a power cable other than that supplied with the product.

- Do not use the power cable with other devices.

(7) Handle the power plug carefully.

Improper handling may result in fire.

- Remove any foreign matter such as dust before inserting the plug into outlet.

- Be sure to insert the power plug fully into outlet.

(8) When removing the power plug from outlet, grasp the plug by hand.

Do not pull on the power cable. It may damage the cable, resulting in fire or electric shock.

(9) Do not place this line checker on an unstable or shaky place such as a rickety table or slope.

The line checker or attachments (socket, ratchet adapter) may fall, resulting in injury.

(10) Do not put this line checker in a place where inflammable liquid or combustible gas is present.

It may cause electric shock or fire.

(11) Be sure to use the specified accessories or options.

Do not use any accessory or option other than those specified in this operating instruction.

Use of any unspecified accessory may result in accident or injury.

Caution

- (1) Do not put this line checker in a place of much moisture or dust, in a place that is exposed to water or direct sunlight, or in a place where the humidity or temperature fluctuates largely.
It may result in electric shock, fire, malfunction, degradation of performance or failure.
- (2) Clean the power plug periodically. Before cleaning, disconnect the plug from outlet and clean the root of the plug and the portion between the blades.
Accumulation of dust at the root of the power plug may cause a short circuit, leading to fire.
- (3) If this line checker is not to be used for a long time, be sure to disconnect the power plug from outlet for safety's sake.
- (4) Before moving this line checker to another place, be sure to turn off the power, remove the power plug from outlet and disconnect all connecting cables. When moving the line

checker, avoid shock or vibration to it.

It may damage the power cable or connecting cables, resulting in fire, electric shock or malfunction.

- (5) Do not use this line checker to conduct measurements beyond its capacity.
For safe and efficient operation, use this line checker to measure the torque wrenches suited to the capacity.
Measurement beyond the capacity may cause accident or damage.
- (6) Check for any damaged parts.
Before use, check the line checker, accessories and other parts for damage and make sure that it operates normally and fulfills the specified functions.
Check the parts and all other portions that may affect the operation for damage, installation status, etc.
For replacement or repair of damaged parts, contact your nearest distributor or TOHNICHI MFG. CO., LTD.

Precautions for Use

For proper and safe use

- (1) Do not use with a power voltage other than in the range of AC100V to 240V.
Use the power cable supplied with the line checker. If the line checker is used with AC 125V or more, prepare a power cable conforming to the power supply voltage and the standard.
- (2) To prevent electric shock or failure due to static, insert the plug of the power cable to an outlet (three-wire type) with a protective earth terminal which is properly grounded using the supplied 3-wire power cable.
If power is supplied from a two-wire outlet using a 3P-2P conversion adapter, connect the ground terminal of the 3P-2P conversion adapter to ground.
If a 3-wire outlet is not available and it is difficult to ground with the ground terminal of the 3P-2P conversion adapter, connect the F.G. terminal on the rear panel to ground.
- (3) Do not use this torque wrench checker in an environment

other than that specified in the operating instruction.

- (4) Do not disassemble or modify this torque wrench checker.
- (5) Before use, make a pre-operation inspection and check the settings.
- (6) If this torque wrench checker gets wet with water or grease, it may break down or burn out. Be careful not to drop water or grease.
- (7) Do not let this torque wrench checker fall or bump. It may result in damage or failure.
- (8) Use this torque wrench checker within the measurement range specified in the operating instruction.
- (9) Be sure to conduct a periodic inspection.
- (10) Before make measurement, make sure that "zero" is displayed.
Should the line checker give out abnormal smell or catch fire during use, stop using it immediately. Then, move the line checker to a safe place and contact your nearest distributor or TOHNICHI MFG. CO., LTD.

Contents

1. Features	4
2. Specifications	5
3. Names of Parts	6
3-1. Indicator and Operating Parts	6
3-2. Right Side of Checker	7
4. How to Use	8
4-1. Handling	8
4-2. Measurement.....	8
4-3. Deletion of Data	8
4-4. Statistical Processing Function.....	9
4-5. Auto Memory/Reset	9
4-6. Auto Zero Adjustment	9
4-7. Over-Torque Alarm	10
4-8. Error Display	10
5. Various Settings	11
5-1. Measurement Unit Selection.....	11
5-2. Setting of Auto Memory/Reset	11
5-3. Communication Setting.....	12
5-4. Checking/Setting of Time	13
6. External Output Function	15
6-1. Printer Output	15
6-2. PC Output.....	16
7. Others	17
7-1. How to Assemble Hexagon Head Adapters	17
7-2. Optional Accessories	17

1 Features

Model LC2-G is a digital line checker designed for daily inspections of torque wrenches near the assembly lines, and it has the following features.

- Economical and easy to operate.
- The built-in clock keeps track of time and date when measurements were taken.
- The over-torque prevention function enables reading of the operating torque of click type torque wrench.
- Units of measure include Newton (cN·m, N·m), Metric (kgf·cm, kgf·m) and American (lbf·in, lbf·ft).
- Wide measurement range - one line checker can measure many types of torque wrenches.
- Adapters with hexagon heads are free to be combined according to the size of the torque wrench to be checked. (See Fig. 1.)
- Up to 99 data can be stored. The line checker has an RS232C-compliant output connector as standard, and it can be easily connect to a PC or the Tohnichi printer.
- With the newly added statistical processing function, arithmetic operations of maximum, minimum and average values on measured data can be performed.
- Adaptable to AC100-240V±10%.
- This line checker has CE marking and can be used in EU without problem.

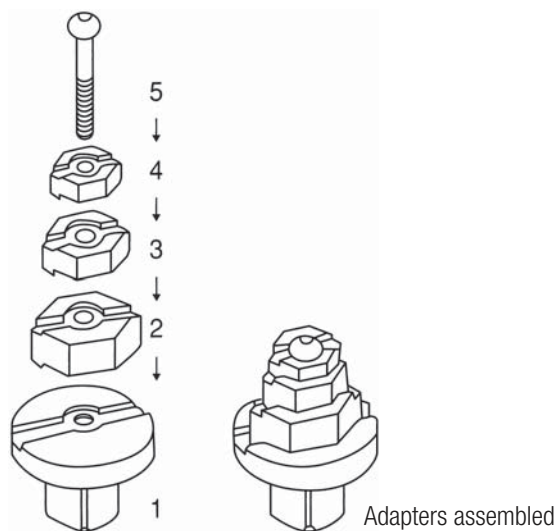

Fig. 1

- ※ Be sure to apply force at the grooved line or dot of torque wrench handle during measurement.
- ※ When a vertical type torque wrench checker is used for calibrating torque wrenches, the head weight of click type torque wrench should be added as error and the tare of dial or flat torque wrench is added as error. For more accurate calibration, a torque wrench tester with a loading device, such as Model TF, TCC, DOTE3-G or DOT, is recommended.
- ※ To make zero adjustment, remove the torque wrench from the checker and press "C" key or turn the power OFF or ON under unloaded condition.

2 Specifications

Model		LC20N2-G					LC200N2-G				LC1000N2-G		
Measurement Mode		PEAK			RUN	PEAK			RUN	PEAK		RUN	
Torque Range	Newton [cN·m]	Min.-Max.	50.0-99.5	100-999	1000-2000	50.0-2000	-			-	-		-
		1 digit	0.5	1	10	0.5	-			-	-		-
	Newton [N·m]	Min.-Max.	0.500-0.995	1.00-9.99	10.0-20.0	0.500-20.000	5.00-9.95	10.0-99.9	100-200	5.00-200.00	50.0-99.8	100-1000	50.0-1000.0
		1 digit	0.005	0.01	0.1	0.005	0.05	0.1	1	0.05	0.2	1	0.2
	Metric [kgf·cm]	Min.-Max.	5.00-9.95	10.0-99.9	100-200	5.00-200.00	50.0-99.5	100-999	1000-2000	50.0-2000.0	-		-
		1 digit	0.05	0.1	1	0.05	0.5	1	10	0.5	-		-
	Metric [kgf·m]	Min.-Max.	-			-	-			-	5.00-9.98	10.0-100.0	5.00-100.00
		1 digit	-			-	-			-	0.02	0.1	0.02
	American [lbf·in]	Min.-Max.	5.00-9.95	10.0-99.9	100-174	5.00-174.00	50.0-99.5	100-999	1000-1740	50.0-1740.0	500-998	1000-8800	500-8800
		1 digit	0.05	0.1	1	0.05	0.5	1	10	0.5	2	10	2
	American [lbf·ft]	Min.-Max.	-			-	4.00-9.95	10.0-99.9	100-140	4.00-140.00	36.8-99.8	100-735	36.8-735.0
		1 digit	-			-	0.05	0.1	1	0.05	0.2	1	0.2
Direction		Clockwise											
Accuracy		1 % ± 1 digit											
Display		Fluorescent Display Tube, Counter: 2-digit, Torque: 3-digit (PEAK)/5-digit (RUN)											
Data memory		99 Data (Counter, Time, Torque Data)											
Measurement Mode		PEAK/RUN											
Zero Adjustment		"C" Key, Auto Zero by Power OFF/ON											
Data Output		RS232C-Compliant											
Memory/Reset		Manual/Auto [Changeable in the range from 0.1 to 5.0 sec.]											
Statistical Processing		Number of samples, maximum value, minimum value, and average value											
Power Requirement		AC100-240V											
Socket		9.5 (Double Square) Female				12.7 (Double Square) Female				25.4 (Double Square) Female			
Dimensions		W 278 x D 160 x H 167								W 500 x D 290 x H 186			
Bolt Pitches to fix Checker		244 x 96 4-ø11 (Hex Socket Head Bolt M10)							470 x 170 4-ø13 (Hex Head Bolt M12)				
Weight		Approx. 10.5 kg								Approx. 34 kg			
Accessories	Socket Adapter	No.270 9.5 (Male) x 6.35 (Female)				No.272 12.7 (Male) x 9.5 (Female)				No.274 19.0 (Male) x 12.7 (Female)			
										No.275 25.4 (Male) x 19.0 (Female)			
	Hexagon Head Adapter	No.282 [8,10,12,13,14,17 (each 1 pc.), Base Adapter (1 pc.), Driver Adapter (1 pc.)]				No.280 [8,10,12,13,14,17,19,22 (each 1 pc.), Base Adapter (2 pcs.)]				-			
	AC Adapter	BA-3											
Fixing plate to		-				-				Attached (Connected), Eyebolt M12			
Options		Battery Pack (BP-100), Calibration Kit, Printer, Data File System, Supporting Board for Vertical Setting (for LC1000N2-G)											

3 Names of Parts

3-1. Indicator and Operating Parts

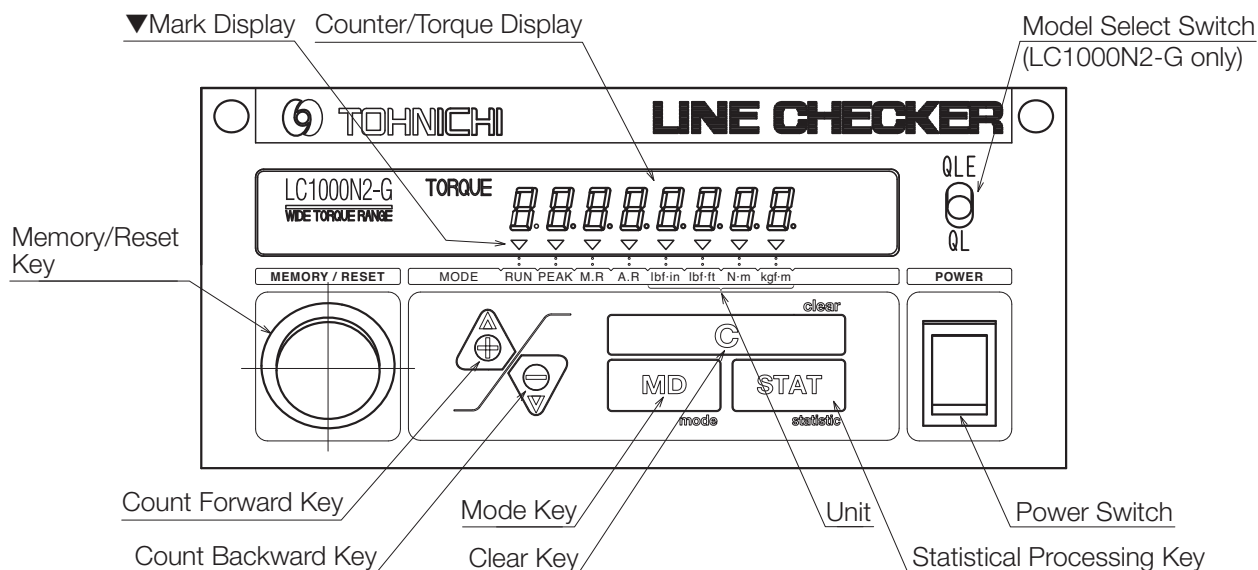

(1) Counter/Torque Display

Displays the counter, torque value and measurement time.

(2) ▼ Mark Display

- RUN: Lights up when RUN mode is selected.
- PEAK: Lights up when PEAK mode is selected.
- M.R: Lights up when Auto memory/Reset is not set in the PEAK mode. Lights up in the RUN mode.
- A.R: Lights up when Auto memory/Reset is set in the PEAK mode.
- Unit: ▼ appears on the unit (lbf-in, lbf-ft, cN·m, N·m, kgf-cm, kgf-m) selected.

(3) Count Forward Key (▲ Key)

Moves the counter forward by one or continuously to read out a measured data.

When a measured data exists, the measurement time is displayed for about 0.5 seconds, and then the torque is displayed.

When the counter is continuously moved forward, the measurement time is not displayed.

(4) Count Backward Key (▼ Key)

Moves the counter backward by one or continuously to read out a measured data.

When a measured data exists, the measurement time is displayed for about 0.5 seconds, and then the torque is displayed.

When the counter is continuously moved backward, the measurement time is not displayed.

(5) Clear Key (C Key)

In the PEAK mode, the peak value is reset. Or, the stored data is cleared. In the RUN mode, auto zero adjustment is performed.

(6) Statistical Processing Key (STAT Key)

This is a key for selecting the number of samples, maximum value, minimum value or average value.

(7) Mode Key (MD Key)

This is a key for selecting the RUN mode or PEAK mode.

(8) Memory/Reset Key (MEMORY/RESET)

Stores the measured data (measured torque, measurement date and time) and moves the counter forward by one.

(9) Model Select Switch (LC1000N2-G only)

Set the switch to QL or QLE according to the torque wrench to be measured.

In the QL mode, measurements can be made within the range from 50 to 600 N·m. Use this mode when measuring torque wrenches, such as QL and CL.

In the QLE mode, measurements can be made within the range from 100 to 1000 N·m. Use this mode when measuring torque wrenches with extension handles, such as QLE, CLE and DQLE.

(10) Power Switch

Turns the power to ON or OFF.

3-2. Right Side of Checker

(1) Power jack (12V, 1A, Center positive)

Connect the supplied AC adapter (BA-3).

(2) RS232C output connector

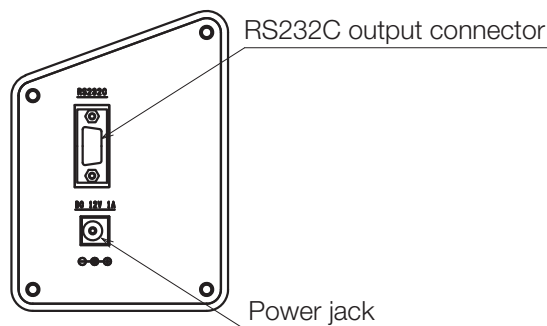

4 How to Use

4-1. Handling

- (1) Place the LC2-G on a sturdy and stable workbench in a horizontal position and fix it with screws.
- (2) Connect the AC adapter to the power jack on the side of the main unit. Make sure that the power switch is in the off position, and then, insert the plug into an outlet.
- (3) Turn on the power switch. (After the power is turned on, leave the unit as it is for 30 minutes or more.)
- (4) Conduct the following settings:
Auto memory/reset setting, communication setting, and clock setting
For the setting procedures, see "5. Various Settings".
- (5) Install the adapters suitable for the torque wrench to be measured.

4-2. Measurement

- (1) Using the MD key, set the measurement mode suitable for the torque wrench to be measured.
Click type torque wrench (QL, SP, etc.) : PEAK hold mode (PEAK)
Dial direct reading type torque wrench (DB, F, etc.) : RUN mode (RUN)
- (2) Make auto zero adjustment.
For the adjustment procedure, see "4-6. Auto Zero Adjustment".
- (3) Check the measurement torque of the torque wrench.
- (4) Set the torque wrench and apply force at the grooved line or dot of torque wrench handle until you hear a click when the measuring point is reached.
- (5) Release the load from the torque wrench. For manual memory/reset, press the Memory/Reset key. The measured data (the measured value and time) is stored, and the counter is moved forward by one and is reset. For auto memory/reset, release the load. The measured data is automatically stored, and the counter is moved forward by one and is reset.
- (6) Repeat the above steps (4) and (5) by the required number of times.

4-3. Deletion of Data

- (1) To delete one data:
Using ▼ or ▲ key, display a data to be deleted and press "C" key. The data will be deleted.
- (2) To delete data between two selected count values:
Using ▼ or ▲ key, display the last count value of data to be deleted and then, press STAT key. "ST" will be displayed. Using ▼ or ▲ key, display the first count value of data to be deleted and then, press STAT key. With any of "n", "HI", "Lo" or "Av" on the display, press "C" key while pressing "STAT" key. The data between the two selected values will be deleted.

(3) To delete all stored data:

Turn on the power while pressing Memory/Reset key, and all stored data will be deleted.
(When the counter is displayed, release Memory/Reset key.)

Caution

※ Before deleting data, recheck whether or not the data should be deleted.

4-4. Statistical Processing Function (number of samples, maximum value, minimum value and average value)

(1) Using ▼ or ▲ key, display the last count in the data range to be subjected to statistical processing.

(2) Press STAT key once, and "ST" is displayed. Using ▼ or ▲ key, display the first count in the data range to be subjected to statistical processing.

Press STAT key, and the sampling number "n", maximum value "HI", minimum value "Lo" and average value "Av" in the specified data range are displayed.

4-5. Auto Memory/Reset

If the maximum measured value is held on the display and the load is released, after a lapse of any (preset) time between 0.1 and 5.0 seconds, the measured value is stored, the counter is moved forward by one and is reset.

4-6. Auto Zero Adjustment

When the torque is lower than the value indicated in the table below, press "C" key or turn the power OFF/ON. Auto Zero function will be activated.

Before conducting the above operation, remove the torque wrench. If you make auto zero adjustment while the torque wrench is set on the checker, the tare of the torque wrench is added as error. If the torque wrench is removed during the operation, the measured torque value remains and zero is not displayed. In such cases, press "C" key again under no load condition.

LC20N2-G	1 N·m
LC200N2-G	10 N·m
LC1000N2-G	50 N·m

If the torque load exceeds the above value, "Err9" is displayed.

<<When "Err9" is displayed>>

- Under no load condition, press "C" key.
 - * If the "Err9" message disappears, the line checker functions properly.
- If the "Err9" message does not disappear, turn OFF the power, and then turn it ON again.
 - * If the "Err9" message remains displayed, the torque sensor or the plated circuit may have any problem.

4-7. Over-Torque Alarm

If the torque exceeds 110% of the maximum measurement value, bars appear on the display and flash for protection of the instrument.

4-8. Error Display

The LC2-G has a self-diagnosis function. When a problem occurs, any of the error messages from Err1 to 9 is displayed.

<<When any of Err1 to 5 is displayed>>

- Turn OFF the power switch. Then, without touching any key, turn ON the power again.
 - * If the "Err" message disappears, the line checker functions properly.
 - * If the "Err" message remains displayed, the LC2-G needs repair. Contact your nearest distributor or TOHNICHI MFG. LO., LTD.

<<When "Err8" is displayed>>

- * The LC2-G needs repair. Contact your nearest distributor or TOHNICHI MFG. LO., LTD.

<<When "Err9" is displayed>>

- Under no load condition, press "C" key.
 - * If the "Err9" message disappears, the line checker functions properly.
- If the "Err9" message does not disappear, turn OFF the power, and then turn it ON again.
 - * If the "Err9" message remains displayed, the LC2-G needs repair. Contact your nearest distributor or TOHNICHI MFG. LO., LTD.

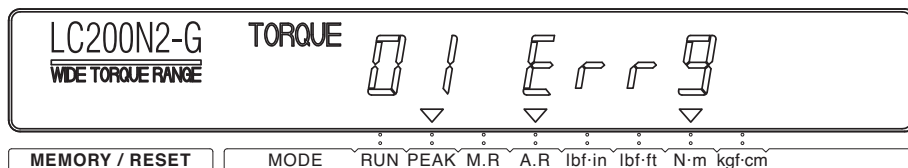

5 Various Settings

Under no load condition, press keys, "C", "STAT" and then "MD" in sequential order. The LC2-G is ready for setting.

<<Measurement mode → Unit (for Metric/American Models only) → Auto Memory/Reset → Output format → Communication baud rate → Data length → Parity → Time (hour/minute/second) → Date (year/month/day) → Measurement mode>>

5-1. Measurement Unit Selection

Using ▼ or ▲ key, select the unit and press STAT key for setting.

If "C" key is pressed, the setting is canceled and the display goes back to the measurement mode.

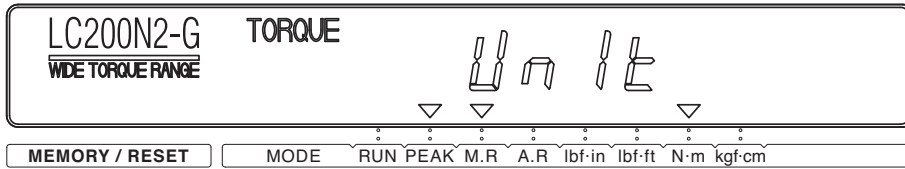

5-2. Setting of Auto Memory/Reset

Using ▼ or ▲ key, select any time between 0.1 to 5.0 seconds and press STAT key.

For manual memory/reset, press STAT key while "0.0" is displayed.

If "C" key is pressed, the setting is canceled and the display goes back to the measurement mode.

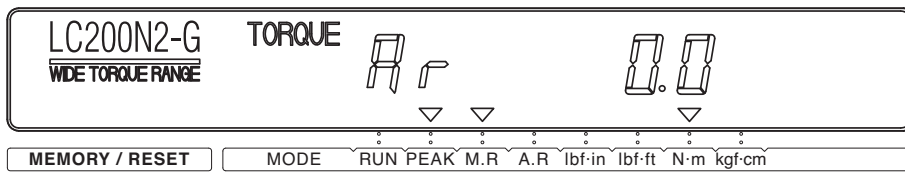

5-3. Communication Setting

(1) Output Format Setting (Factory default: PC Output)

The RS232C output format is set at Printer output or PC output.

Using ▼ or ▲ key, select "Prn" for printer output or "PC" for PC output and press STAT key for setting. Now, the display is ready for communication baud rate setting.

If "C" key is pressed, the setting is canceled and the display goes back to the measurement mode.

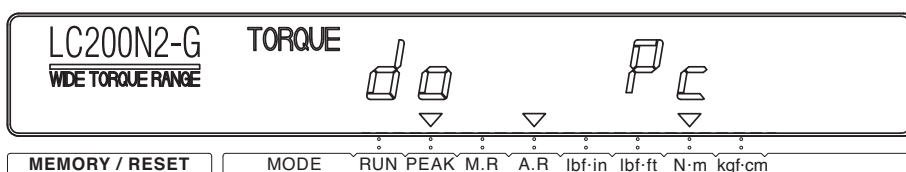

(2) Communication Baud Rate Setting (Factory default: 2400 bps)

The communication baud rate is set as follows:

Using ▼ or ▲ key, select "2400", "4800", "9600" or "19200" and press STAT key for setting. Now, the display is ready for data length setting.

If "C" key is pressed, the setting is canceled and the display goes back to the measurement mode.

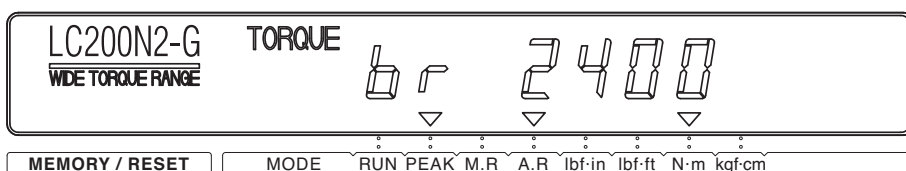

(3) Data Length Setting (Factory default: 7bit)

The communication data length is set as follows:

Using ▼ or ▲ key, select "7bit" or "8bit", and press STAT key for setting. Now, the display is ready for parity setting.

If "C" key is pressed, the setting is canceled and the display goes back to the measurement mode.

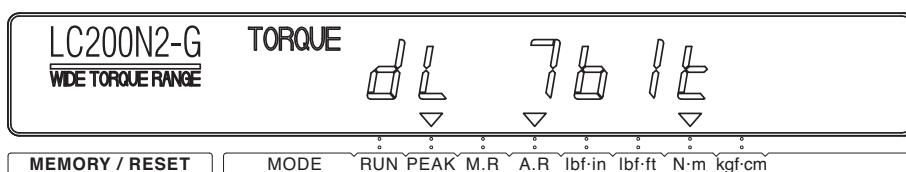

(4) Parity Setting (Factory default: None)

The communication parity is set as follows:

Using ▼ or ▲ key, select "nonE" for none, "EvEn" for even number or "odd" for odd number.

Then, press STAT key for setting. Now, the display is ready for clock checking.

If "C" key is pressed, the setting is canceled and the display goes back to the measurement mode.

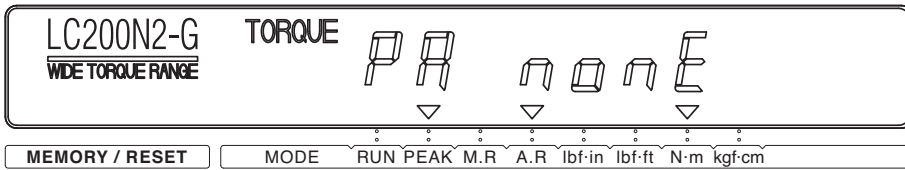

5-4. Checking/Setting of Time

(1) Time Checking

The time checking procedure is as follows: Press ▼ or ▲ key and check the time (hour/minute/second) and date (year/month/day).

To change the setting, press STAT key. The display becomes in the clock setting mode.

If "C" key is pressed, the setting is canceled and the display goes back to the measurement mode.

(2) Time Setting (hour/minute/second)

The time setting procedure is as follows:

"Hour" is flashing. Press ▼ or ▲ key and set the hour. Then, press STAT key for setting. The display is ready for "minute" setting.

To skip the setting, press "MD" key. The display will be ready for the next setting.

If "C" key is pressed, the setting is canceled and the display goes back to the measurement mode.

In the same way, set "minute" and "second". After completion of the settings, the display becomes in the date setting mode.

Note that "00" is displayed on the field of "second".

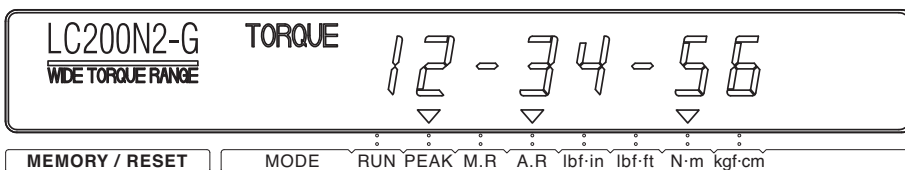

(3) Date Setting (year/month/day)

The date setting procedure is as follows:

"Year" is flashing. Press ▼ or ▲ key and set the year. Then, press STAT key for setting. Now, the display is ready for "month" setting.

To skip the setting, press "MD" key. The display will move to the next setting.

If "C" key is pressed, the setting is canceled and the display goes back to the measurement mode.

In the same way, set "month" and "day". After completion of the settings, the display returns to the measurement mode.

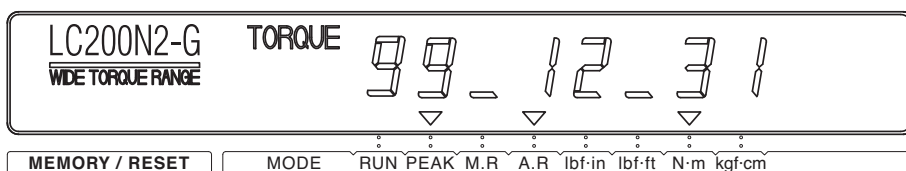

6 External Output Function

6-1. Printer Output

Connect the LC2-G and the Tohnichi printer (EPP16M2) using a printer cable (Catalog No. 382).

(1) Progressive printing

Press the Memory/Reset key. In the progressive printing, the results of statistical processing are not printed. In the Auto Memory/Reset mode, the results are automatically printed out.

(2) Continuous printing

Display the last count value in the print range and press STAT key. "ST" is displayed. Using ▼ or ▲ key, display the first count value in the print range and press STAT key. Then, press ▲ key while "n" is displayed.

The data, sampling number "n", maximum value "MAX", minimum value "MIN" and average value "AVE" in the specified range are printed out.

(3) Printing of only statistical processing value

Display the last count value in the print range and press STAT key. "ST" is displayed. Using ▼ or ▲ key, display the first count value in the print range and press STAT key. Then, press ▼ key while "n" is displayed.

The sampling number "n", maximum value "MAX", minimum value "MIN" and average value "AVE" in the specified range are printed out.

Continuous printing example

```

1 :  1 2 6  N · m
1 2 / 1 0  1 3 : 3 0
2 :  1 2 5  N · m
1 2 / 1 0  1 3 : 3 1

7 :  = = = = N · m
0 0 / 0 0  0 0 : 0 0
8 :  1 2 2  N · m
1 2 / 1 0  1 3 : 4 0
- - - - -
n = 7
M A X  1 2 7  N · m
M I N  1 2 2  N · m
A V E  1 2 5  N · m
    
```

Counter: Torque Unit
 Measurement date: Hour Minute

When the measured value displayed on the LC2-G is "0" or "----", the value is excluded from the statistical processing, and "===" is printed out.

6-2. PC Output

Data format: RS232C-compliant

Transmission system: Start-stop synchronization serial

Baud rate: 2400/4800/9600/19200 bps

Data length: 7bit/8bit

Stop bit: 1bit

Parity: None/Even number/Odd number

Format

R	E	,	0	1	,	0	1	2	.	3	CR	LF
Header			Counter			5-digit torque (including decimal point)					Delimiter	

7 Others

7-1. How to Assemble Hexagon Head Adapters

Select three hexagon head adapters that are frequently used from the supplied adapters. Assemble the three adapters onto the fixed base and tighten them with the fixing screws. Then, place the assembled adapters onto the holder on the left side of the checker. (See Fig.1)

7-2. Optional Accessories

- 1) Tohnichi printer EPP16M2
 - 2) Cable for printer Catalog No. 382
 - 3) Cable for PC Catalog No. 383
 - 4) Calibration kit
 - TCL50N (Applicable model: LC20N2-G)
 - TCL200N (Applicable model: LC200N2-G)
 - TCL1000N (Applicable model: LC1000N2-G)
- * TCL1000N is a made-to-order item.

LC2-G Dimensions

■ LC20N2-G, LC200N2-G

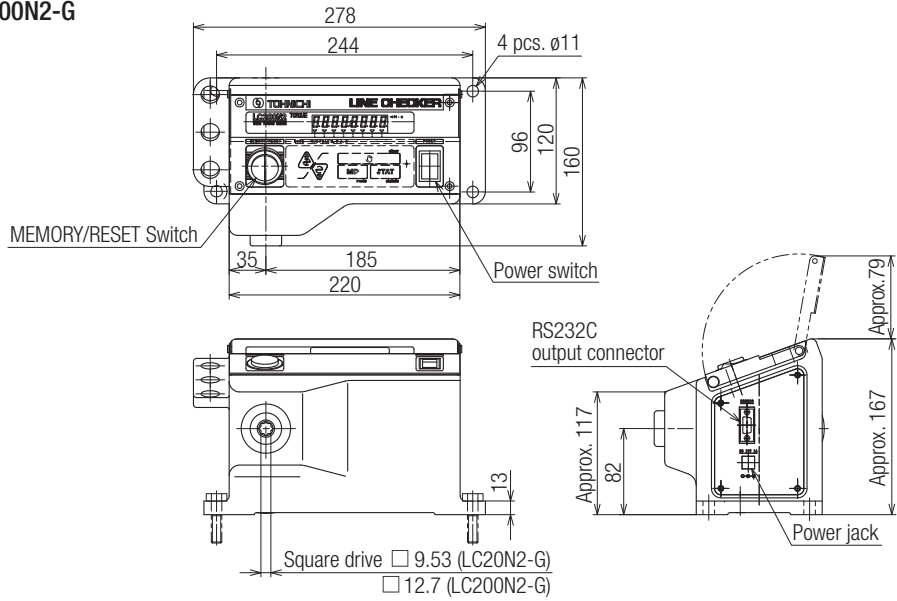

■ LC1000N2-G

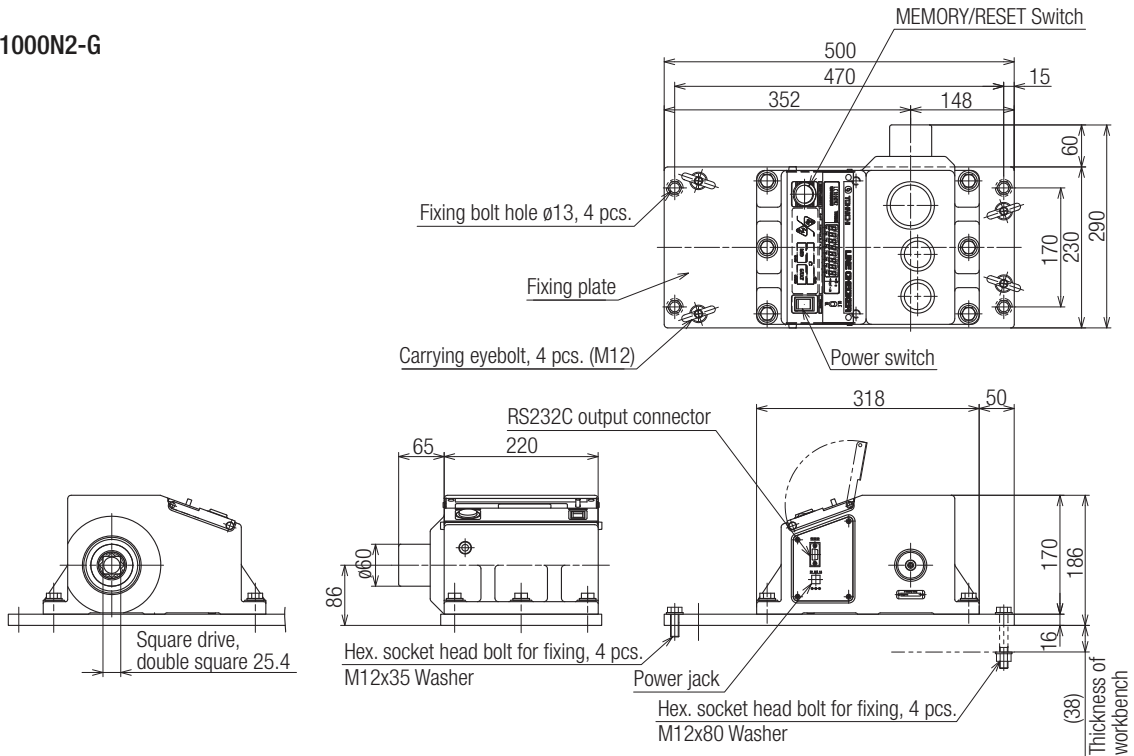

Designs and specifications are subject to change without notice.



■ **TOHNICHI MFG. CO., LTD.**

TEL: +81-(0)3-3762-2455 FAX: +81-(0)3-3761-3852
2-12, Omori-kita, 2-Chome Ota-ku, Tokyo 143-0016, JAPAN
E-mail: overseas@tohnichi.co.jp
Website: <http://tohnichi.jp>

■ **N. V. TOHNICHI EUROPE S. A.**

TEL: +32-(0)16-606661 FAX: +32-(0)16-606675
Industrieweg 27 Boortmeerbeek, B-3190 Belgium
E-mail: tohnichi-europe@online.be
Website: <http://www.tohnichi.be>

■ **TOHNICHI AMERICA CORP.**

TEL: +1-(0)847-272-8480 FAX: +1-(0)847-272-8714
677 Academy Drive, Northbrook, Illinois 60062, U. S. A.
E-mail: inquiry@tohnichi.com
Website: <http://www.tohnichi.com>

■ **TOHNICHI AMERICA CORP. - Atlanta Office**

TEL: +1-(0)770-944-2734 FAX: +1-(0)770-944-2735
561 Thornton Road, Suite U, Lithia Springs, Georgia 30122

■ **TOHNICHI SHANGHAI MFG. CO., LTD.**

东仁扭矩仪器(上海)有限公司
TEL: +86-(021)3407-4008 FAX: +86-(021)3407-4135
Factory 2 No.58 lane 4018. Hua Ning Road,
Industry Park Xin Zhuang Minhang Shanghai, 201108 P. R. China