

DIGITAL TORQUE GAUGE MODEL ATGE-G

OPERATING INSTRUCTION

ATGE-G ATGE-G Model



ATGE5CN-G
(display put together)



ATGE5CN-G
(display put apart)



ATGE5CN-G
(display removed and
optional table attached)



To use this product properly and safely, please read this manual carefully before use. If you have any question about the product and its operations, please contact your nearest distributor or TOHNICHI MFG. CO., LTD.

Safety Precautions

To customers: Before using this product, please read this operating instructions carefully to use it properly. If you have any question, please contact your nearest distributor or TOHNICHI MFG. CO., LTD. This operating instruction should be stored in a safe place.



Safety Symbol



This symbol is used for drawing attention to "safety precautions". If you see this symbol in this operating instruction, attention should be paid to safety. Take preventative actions according to the description and conduct "safe operations and proper control".

Signal Words

The signal words are the headers which indicate the level of hazard that should be know for human safety and in handling devices. The signal words for safety are "Danger", "Warning" and "Caution" depending on the level of hazard to human. The signal words are used with the safety symbol to indicate the following situations

- " Danger": Indicates an imminently hazardous situation which, if not avoided, will result in death or serious injury.
- " Warning": Indicates a potentially hazardous situation which, if not avoided, could result in death or serious injury.
- " Caution": Indicates a potentially hazardous situation which, if not avoided, may result minor or moderate injury.

 **Warning**

- **Do not use this instrument in an atmosphere of flammable gas or steam.**
 - Use in such an atmosphere may cause a fire.
- **Disassembly or modification of the instrument is prohibited.**
 - It may result in loss of safety, degradation in functions, shortening of product life, or failure.
- **Do not heat or throw batteries into fire.**
 - Batteries may explode if they are heated or thrown into fire.
- **Consider the environment of the workplace.**
 - Do not use the instrument body and battery in the rain or in damp or wet places.
 - Use in such a place may cause an electric shock or smoking.
- **Make sure to use the specified accessories or options.**
 - Do not use any accessory or option other than those specified in this operating instruction.
 - Use of any unspecified accessory may result in accident or injury.

 **Caution**

- **Be sure to use a coin shaped lithium battery CR2450 for power source.**
 - Do not use any other battery than that specified in this operating instruction.
- **When inserting the battery, be careful to ensure correct polarity.**
- **Do not use or store the instrument in places subject to high temperature, high humidity, dust, water which may enter the instrument, strong vibration or unstableness.**
 - Use or storage in such a place may cause a failure in the instrument body.
- **Store in an appropriate place when not in use.**
 - Store the instrument in a dry and lockable place. Otherwise, an injury or accident may be caused. Do not store the instrument body and batteries in a place where the temperature may exceed 50 degrees.
 - Storage in such a place may degrade batteries, causing smoking or ignition.
- **For safe and efficient operation, conduct the work with a torque value suited to the capacity of the instrument.**
 - Work with a torque value beyond the capacity may cause an accident.
- **Do not use the instrument for any purpose other than that specified.**
 - Use for any purpose other than that specified may result in an injury.

- **Carefully perform maintenance of the instrument.**
 - For replacement of accessories, follow their operating instructions. If you don't follow the operating instruction, it may cause a failure.
- **Always keep the grip dry and clean and free of oil or grease.**
 - Otherwise, it may result in an injury.
- **Check the parts for damage.**
 - Before use, fully check the case and the other parts for damage and make sure that the instrument operates normally and fulfills the specified functions.
 - Check the parts and all other portions that may affect the operation for damage, abnormality and installation status.
 - For replacement or repair of a damaged case and other parts, contact your nearest distributor or TOHNICHI MFG. CO., LTD.
- **For proper and safe use**
 - Since ATGE-G is designed to measure very small torque, do not apply torque over the maximum capacity.
 - Make sure to hold the chuck holder when opening and closing the three-jaw chuck.
 - Do not bend or pull the cable connecting the gauge and the display.
 - The battery inside ATGE-G is for sample use only, and may not be fully charged.
 - Do not connect ATGE-G to PC by USB cable when a battery is not inside. It may cause malfunction.
 - Do not use any battery other than that specified. (CR2450)
 - Avoid shock or vibration to this instrument.
 - Do not use this product in an environment other than that specified in the operating instruction.
 - Before use, make a pre-operation inspection and check the settings.
 - If this products gets wet with water or grease, it may break down or burn out. Be careful not to drop water or grease.
 - Do not let this product fall or bump. It may result in damage or failure.
 - Use this product within the measurement range specified in the operating instruction.
 - Be sure to conduct a periodic inspection.
 - Before make measurement, make sure that "zero" is displayed.
 - Be sure to perform a daily inspection and calibration at intervals decided in your company.
 - Should this product give out abnormal smell or catch fire during use, stop using it immediately. Contact your nearest distributor or TOHNICHI MFG. CO., LTD.

Contents

1. Features	5
2. Components	5
3. Names of Parts and Descriptions	6
4. Detailed Descriptions of Various Functions	8
5. How to Use	11
5-1. Before use	11
5-2. Rotating ATGE-G itself to measure	12
5-3. Fixing ATGE-G on the table to measure.....	13
6. Operating Examples	15
6-1. Computing function.....	15
6-2. All measurement data output at a time	16
6-3. Delete measurement data	17
7. External Output Specifications	18
8. Procedures of Various Settings	19
8-1. Unit setting.....	19
8-2. PEAK mode change.....	19
8-3. Auto Memory/Reset setting.....	20
8-4. Baud rate setting.....	20
8-5. Buzzer ON/OFF setting	20
9. Change of Battery	21
10. Optional Accessories	22
11. How to Use the USB Adapter	23
12. Specifications	25

1 Features

- (1) Digital torque gauge integrated with the digital display.
- (2) Hand-held type micro capacity torque meter capable for bi-directional use.
- (3) The display is combined with the main body to maximize usability.
- (4) Suited for measuring small torque for precision machines, electronic instruments, and for assembly work.
- (5) Can be used as screwdriver checker for 0.1-5cN·m.
- (6) Three-jaw chuck enable to clamp the object firmly for measurement.
- (7) Equipped with a stopper to prevent over-torque.
- (8) Up to 999 measurement data can be stored. Data can be automatically counted by the auto memory function.
- (9) The number of samples, maximum value, minimum value and average value can be displayed.
- (10) A coin shaped lithium battery (CR2450) allows 10-hour continuous operation with 4-step residual battery indicator.
- (11) Data can be transferred directly to PC through the USB interface.
- (12) Compliant with CE marking for international use including EU.
- (13) Table Attachment is available as option to use ATGE-G fixed on it.
- (14) USB power adapter is available for continuous use.

2 Components

- (1) Main unit1 set
- (2) Coin shaped lithium battery (CR2450)
(already set inside when shipping).....1 set
- (3) Operating instruction1 set
- (4) Carrying case1 set

3 Names of Parts and Descriptions

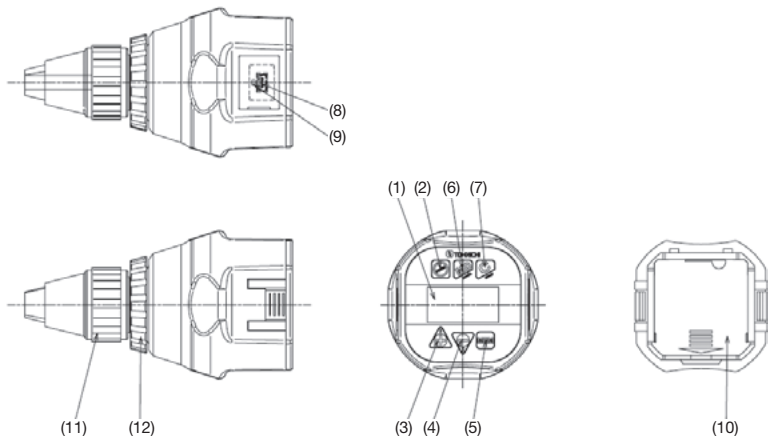

(1) Liquid Crystal Display

Displays the counter, auto memory, residual battery indicator, units and torque value.

[Display]

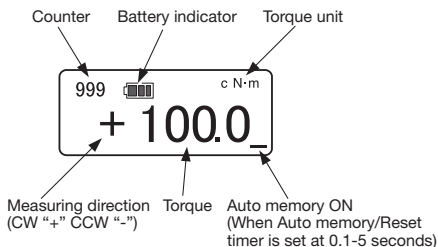

(2) Power Switch

Turns the power to ON/OFF. When the power is turned ON, key checks are conducted automatically.

(3) Count Forward Key

Moves the counter forward by one or continuously to read out a measured data. If you keep it pushed, it can fast-forward.

(4) Count Backward Key

Moves the counter backward by one or continuously to read out a measured data. If you keep it pushed, it can fast-forward (backward).

(5)  **Memory Key**

Saves the measured data and moves the counter forward to the next. The displayed measurement data is output to the external device. When auto memory (0.1 to 5 sec.) is in effect, MEM key cannot be used for saving.

(6)  **Mode Key**

This key selects the number of sample, max/min/average value, etc. Keep this key pushed to go to various settings (changing torque unit, auto memory/reset, baud rate, buzzer ON/OFF).

(7)  **Clear Key**

In the PEAK mode, this key is used to reset the peak value or to delete the stored data.
In the RUN mode, auto zero adjustment is performed.

(8) **External Output Terminal**

This is the terminal for connecting the USB connection cable (option).

(9) **Reset Switch**

If any display error or malfunction occurs, press the reset switch.

(10) **Battery Cover**

A coin-shaped lithium battery (CR2450) is set inside.

At the time of purchase, an insulated film is inserted. Take out this film before use.

(11) **Three-jaw Chuck**

Clamps the object to be measured.

(12) **Chuck holder**

When clamping an object with the three-jaw chuck, hold this part to tighten or loosen in order to hold the object.

Note : Hold the chuck holder when opening/loosening the three-jaw chuck.

4 Detailed Descriptions of Various Functions

(1) Continuous display (RUN mode)

When the counter is set at 000, it is in RUN mode where the displayed value increases as torque is applied, and returns to zero as it is released.

(2) Maximum value display (PEAK mode)

2 kinds of PEAK modes are selectable as follows.

PEAK measuring mode (P-1)

When the counter is set at any value in the range of 001-999, it is in PEAK mode, where the torque value keeps the peak value after releasing the torque (Peak value can be captured only when the value exceeds the 15% of the max capacity torque).

Note * If you try to measure an object which may generate physical impact to ATGE sensor (such as rotary slip type torque screwdriver), it may cause it to show a very high value.

Torque screwdriver measuring mode (P-2)

Set the counter to 000-999, torque value increases as torque is applied, and it holds the peak value as it clicks at the set torque.

(3) Auto Zero function

In RUN mode, press the clear key to activate the auto zero function. (However, the torque load must be within about 20% of the maximum value).

<<When Err 9 is displayed>>

- Under no load condition, press the power switch and the clear key.
 - If Err 9 message disappears, it functions properly.
 - If Err 9 message remains displayed, press the reset switch, and then press the power switch and the clear key again. If the Err 9 message still remains displayed, the sensor or the circuit board may have a problem. Contact TOHNICHI to seek further assistance.

<<When Err 0 is displayed>>

Err 0 may appear if Auto Zero is activated while the torque value is still in unstable conditions.

- Under stable condition, press clear key again.
 - If Err 0 message disappears, then it can be used normally.
 - If Err 0 message remains displayed, press reset switch, press clear again under stable condition. If it still remains, there may be a sensor problem. Contact TOHNICHI to seek further assistance.

Note * When Err 0 or Err 9 is displayed, if the displayed torque value is more than 15% of the torque value, turn off the power or take out the lithium coin battery, otherwise it consumes battery.

- * Auto zero adjustment must be done under no load condition.
- * When "Err 0" of "Err 9" remains on the display, turn the power off to save electricity.
- * For Auto zero operation, load to measuring direction then released load and push "C" key.

(4) Error message

When turning on the power, automatic key check will be activated.

If there is anything wrong with the key functions, the following error message appears.

<<Err 1: The Count Forward Key is left pressed>>

<<Err 2: The Count Backward Key is left pressed>>

<<Err 3: The Memory Key is left pressed>>

<<Err 4: The Clear Key is left pressed>>

<<Err 5: The Mode Key is left pressed>>

<<Err 8: There is something wrong with the internal memory>>

Err 1 to Err 5 or 8 is displayed

- Turn off the power switch. Then, without touching any other key, turn on the power again. If the "Err" message disappears, the torque gauge functions properly.
- If the "Err" message remains displayed, turn off the power once, then press the power switch and the clear key at the same time. If it still remains, the membrane switch, the circuit board or the internal memory may have problem. Contact TOHNICHI to seek further assistance. If the "Err" remains displayed, it is advised to turn off the power or take out the lithium battery to stop electricity consumption.

(5) Auto Memory/Reset function

In PEAK mode (Counter 001-999), the peak value will be automatically saved by the set timing. After torque is released, and the counter will be sent forward to the next one. Auto Memory/Reset function will be disabled if you set it to 0.0.

(6) Auto Power OFF function

Without any key operation or torque for 3 minutes, the power will be automatically turned off. When the residual battery reaches a certain point and "- - -" appears on the display, it turns off after 1 minute.

Note * Please note that "Auto Power OFF function" does not work when using the USB power supply.

(7) Residual battery indicator

The LCD indicates the remaining battery status in 4 steps.

There is enough battery remaining.



Remaining battery amount is not enough. The battery life is half of the full operating time.



It is almost time to replace batteries.



Battery alarm

There is no battery remaining. Immediately charge batteries "- - - -" is displayed on the LCD, and only power switch can be operated. In one minute after this battery alarm occurs, the power will be turned off.

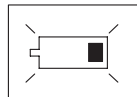

Note * "Battery Indicator" will not work when using the USB power supply.

(8) Over torque alarm

If the torque exceeds about 105% of the maximum measurement torque, the torque value and "---" appears alternately and a buzzer sounds (When Buzzer setting is ON).

(9) Over torque alarm and peak hold starting torque

Unit (cN·m)

Model	Torque Range		1digit	110% of max torque	15% of max torque	Auto zero range
	Min.	Max.		Over torque alarm	Peak hold starting torque	
ATGE05CN-G	0.100	0.500	0.001	0.550	0.075	0.100
ATGE1CN-G	0.200	1.000	0.001	1.100	0.150	0.200
ATGE2CN-G	0.400	2.000	0.002	2.200	0.300	0.400
ATGE5CN-G	1.000	5.000	0.005	5.500	0.750	1.000
ATGE10CN-G	2.00	10.00	0.01	11.00	1.50	2.00
ATGE20CN-G	4.00	20.00	0.02	22.00	3.00	4.00

5 How to Use

5-1. Before use

- Before using the torque gauge, open the display portion and remove the battery insulating sheet.

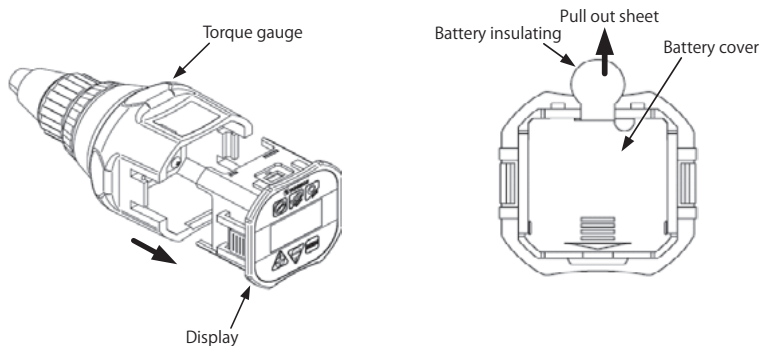

- Turn on the power of the torque gauge and make sure that there is enough battery remaining.
- If the battery indicator is flashing, change the batteries.

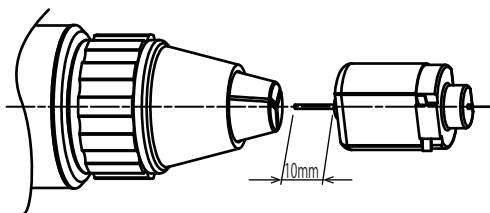

- To hold an object firmly in the chuck, the length should be 10mm or longer.

- Note
- * The body and display part is connected by a cable, be careful not to damage the cable.
 - * Be careful not to pinch the cable when putting the display part into the body.

5-2. Rotating ATGE-G itself to measure

- Before measurement, check that ATGE-G shows 0 on the display. If it is not zero, push clear key at no load condition and get 0.
- Hold the chuck holder fixed and open the three-jaw chuck. Place the object inside the three-jaw chuck.
- Place the object to the center of the three-jaw chuck and close the chuck to fix the object (When you close the three-jaw chuck, make sure to hold the chuck holder fixed).
- Either in RUN mode (000) or PEAK mode (001-999), rotate ATGE-G to measure the torque. It works bi-directionally.

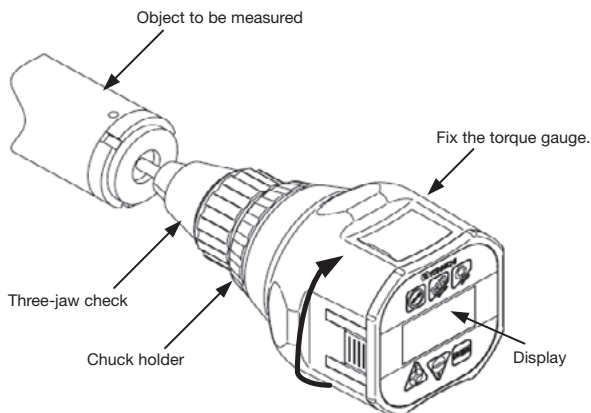

⚠ Make sure to hold the chuck holder when rotating the three-jaw chuck.

Note * Make sure the object is clamped in the center and level is maintained for accurate measurement.

* If the object to measure is too big for the existing three-jaw chuck to measure, a special adapter needs to apply to measure (see below illustration).

* The object and ATGE-G must be set in stable condition when auto zero is conducted.

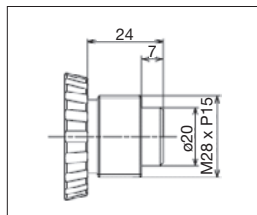

5-3. Fixing ATGE-G on the table to measure

- Take out the display and place ATGE-G on the measuring board with the three-jaw chuck side up.

When measuring an object (other than a screwdriver)

- Before measurement, check that ATGE-G shows 0 on the display. If it is not zero, push clear key at no load condition and get 0.
- Holding the chuck holder fixed, open the three-jaw chuck and put the object inside.
- Place the object to be measured in the center of three-jaw chuck, while holding the chuck holder fixed, tighten the chuck.
- Turn on the power of the torque gauge.
- If the counter is 000, the continuous display (RUN mode) is set. If the counter is 001-999, PEAK mode is set. It works bi-directionally.
- Hold the torque gauge with one hand and rotate the object with the other. Measure the torque either in RUN mode or PEAK mode.

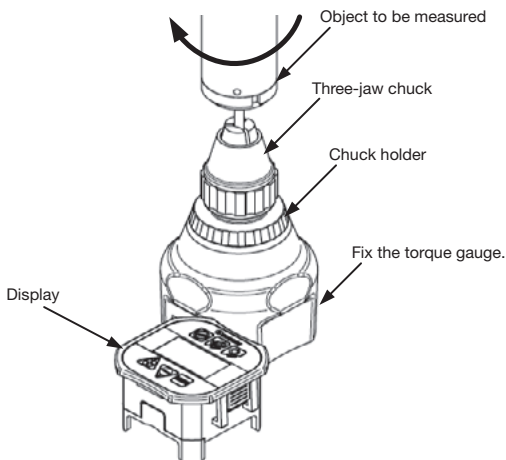

⚠ Make sure to hold the chuck holder when rotating the three-jaw chuck.

When measuring a torque screwdriver

- Set the peak measurement mode to (P-2).
- Before setting the screw driver, turn on the power of ATGE and check the display shows "0". If it is not zero, push clear at no load condition and get zero.

- Holding the chuck holder fixed, open the three-jaw chuck and put the torque screwdriver bit in it.
- Place the torque screwdriver bit in the center of three-jaw chuck. While holding the chuck holder fixed, tighten the chuck, and ensure that the bit is clamped completely.
- Set the counter to 001-999 for peak hold (P-2).
- While holding the torque gauge fixed, turn the torque screwdriver and measure the torque.
- When measuring a rotary slip type screwdriver, measure one click (within 1 sec).

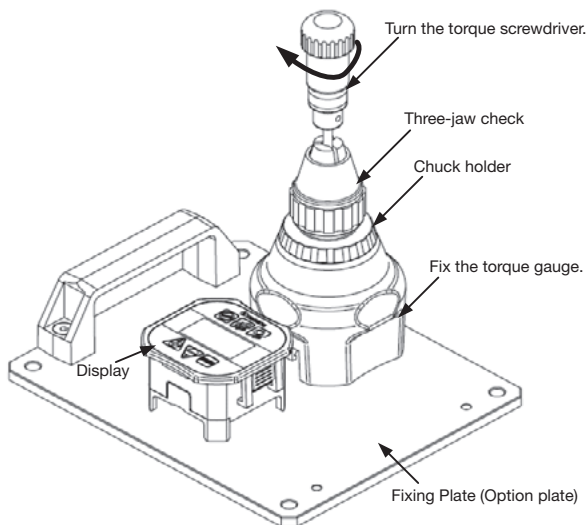

⚠ Make sure to hold the chuck holder when rotating the three-jaw chuck.

Note * Make sure to hold the chuck holder when rotating the three-jaw check, otherwise the torque may transfer to the main body directly and damage the product.

* Make sure to fix the measuring object in the center and keep it level against the torque gauge in order to measure the accurate torque.

* In case that auto-zero be effected when the measuring object is set to ATGE-G, make sure the object and ATGE-G is in stable condition.

* Hold the screw driver upright when measuring.

* Avoid applying any load on the chuck holder.

* The torque setting of the screwdriver must not exceed ATGE-G maximum capacity.

6 Operating Examples

6-1. Computing function

The number of data, maximum value, minimum value and average value of the measurement data in the specified range are calculated.



Using this button, set the counter at the upper limit value in the range of data to be calculated.



Press MD.

Ex.1) To calculate in the range of 001-200:

Set the counter at 200, press the MD key, and Stt at 001.

Ex.2) To calculate in the range of 101-200:

Set the counter at 200, press the MD key, and set Stt at 101.



Using this button, set the counter at the lower limit value in the range of data to be calculated.



Press MD.



(Press C to cancel.)

As you press MD key, the number of data, max value, min. value, average value will be shown in this order (See right).

To cancel the operation, press C key.

Memory display

200 cN-m
+ 30.0_



Start number display

Stt cN-m
001

Blinking



Number of data display

n cN-m
200



Max. value display

HI cN-m
50.0



Min. value display

LO cN-m
20.0



Average value display

AV cN-m
30.0



Memory display

200 cN-m
+ 30.0_

6-2. All measurement data output at a time

All measurement data in the specified range is output at a time to an external device (PC).
Make sure output baudrate is set and USB cable (No.384) is connected in advance.

 Set the counter at the upper limit value in the range of data to be output.

 Press MD.

Ex.1) To output data in the range of 001-200:

Set the counter at 200, press the MD key, and set Stt at 001.

Ex.2) To output data in the range of 101-200:

Set the counter at 200, press the MD key and set Stt at 101.

Ex.3) To output all measurement data:

Set the counter at 999, press the MD key, and set Stt at 001.

 Set the counter at the lower limit value in the range of data to be output.

 Press MD to proceed.

 Press C to cancel.

When the display shows the number of data,

 Press this to output all measurement data.

 Press this to cancel.

Memory display

200  cH-m
+ 30.0_



Start number display

Stt  cH-m
001



Number of data display

n  cH-m
200



Data output start



001  cH-m
+ 38.2



Data output completion

Number of data display
n  cH-m
200

Note) To stop data output, press the Clear key. While data is output, any other key cannot be operated.

6-3. Delete measurement data

Measurement data can be deleted as follows.

(1) Delete 1 data

Display the counter number of data to be deleted.

 Press to delete.

The measurement is deleted.

(2) Delete data in the specified range

 Set the counter at the upper limit value of the data range to delete.

 Press MD.

Ex.1) To delete data in the range of 001-200:

Set the counter at 200, press the MD key, and set Stt at 001.

Ex.2) To delete data in the range of 101-200:

Set the counter at 200, press the MD key, and set Stt at 101.

Ex.3) To delete all measurement data:

Set the counter at 999, press the MD key, and set Stt at 001.

 Set the counter at the lower limit value in the data range to delete.

 Press MD.

 Press C to cancel.

While any of the displays shown in the right box appears, holding the MD key down, press the C key. Then, release both keys.



Measurement data memory is deleted



After deleting, the counter returns to the start counter number and goes back to measurement display.

Memory display



Memory display



Clear start number display



Blinking

Number of data display



Max. value display



Min. value display



Mean value display



7 External Output Specifications

USB Interface		USB1.1 compliant (USB-serial conversion chip used)
Connector		USB mini B-type
Serial Interface	Baud rate	2400/4800/9600/19200 bps (selectable)
	Data length	8 bits
	Stop bit	1 bit
	Parity	None
	Flow control	Not control

• USB Output Method

The USB connection cable and communication driver are optionally available (Part No. 384).

· Preparation (PC)

(1) Install the communication driver to a USB-compliant PC.

(The communication driver is contained in the CD-ROM supplied with the product.)

(2) Make settings of the PC port and communication format.

(For installation procedure and communication settings, see the instruction manual in the CD-ROM.)

· Preparation (ATGE-G)

(3) Turn on the power of ATGE-G.

(4) Select the communication baud rate (2400/4800/9600/19200 bps).

· Communication

(5) Connect the USB connection cable (option) to the PC and ATGE-G.

(6) Start up the communication software (The communication software is not included with the product).

· Data output

(7) Data Output Method (See the "All measurement data output at a time").

* Use the optionally available USB connection cable to connect to a PC.

* Connect the cables to PC before starting up the software. Otherwise, communication may not be established.

* If the ATGE-G and multiple TOHNICHI USB serial output devices (CEM3, R-DT999, ST2) are connected to a PC at the same time, communication may not be established.

* Do not connect ATGE-G to PC with USB cable when no battery is installed, or when the battery is running out (Battery alarm).

• Output Format

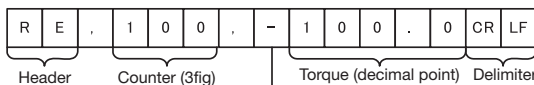

plus (+): nothing is displayed (blank).
minus (-): "-" is displayed.

8 Procedures of Various Settings

This chapter explains various settings.

* Before setting, make sure that the counter shows 000 (RUN mode).

 Press MD for over 2 seconds till the mode setting display appears. Then, release the MD key.

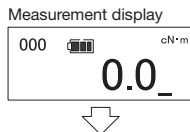

8-1. Unit setting

 Selected torque unit
(cN·m ↔ mN·m ↔ gf·cm ↔ ozf·in ↔ cN·m)

 Press to save the setting and proceed to the next.

 Press to cancel. The display returns to the measurement display.

 Proceed without saving.

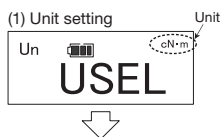

Unit conversion table (Conversion factors)

mN·m	10.000
gf·cm	101.972
ozf·in	1.4162

8-2. PEAK mode change

 PEAK mode change

P-1: PEAK measuring mode

Captures the peak and holds the value.

If you continue to apply torque, measured value will be renewed.

P-2: Torque screwdriver measuring mode.

Holds the torque value upon clicking of the torque screwdriver.

 Press to save the setting and proceed to the next.

 Press to cancel. The display returns to the measuring display.

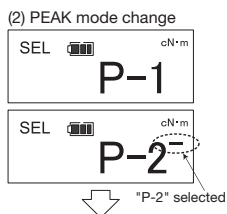

 Proceed without saving.



8-3. Auto memory/Reset setting

 Select the timing of Auto memory/Reset.
(0.0 ⇔ 0.1 ⇔ 0.2 ⇔ 0.3 ⇔ 0.4 ⇔ 0.5 ⇔ 1.0 ⇔ 2.0 ⇔ 3.0 ⇔
4.0 ⇔ 5.0 ⇔ 0.0 sec.)

If you prefer manual saving, set it to 00.

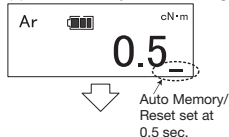

-  Press to save the setting and proceed to next.
-  The display returns to the measurement display.
-  Proceed without saving.

(3) Auto Memory/Reset setting



8-4. Baud rate setting

 Change the baud rate setting
(2400 ⇔ 4800 ⇔ 9600 ⇔ 19200 ⇔ 2400)



-  Save setting and proceed to next.
-  Press to cancel. The display returns to measurement.
-  Proceed without saving.

(4) Baud rate setting



8-5. Buzzer ON/OFF setting

 Switch buzzer ON/OFF.
(ON ⇔ OFF)

-  Save and returns to measurement display.
-  Press to return to measurement display.
-  Return to measurement display without saving.

(5) Buzzer ON/OFF setting

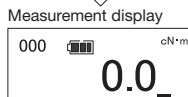

9 Change of Battery

- (1) If the battery alarm is displayed, the battery needs replacement.
- (2) Put apart the display part and slide open the battery cover on the back side of the display.
- (3) Remove the battery from the holder, and replace it with a new battery.

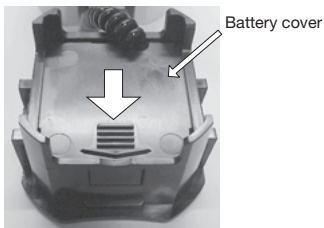

- (4) Slide forward the battery to take it out. (See the arrow)

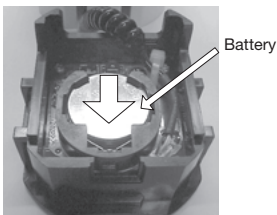

- (5) Keeping the battery forward, pull it up. Remove the battery and replace it with a new one.



- (6) After changing batteries, put back the battery cover.

Note * Use the Coin-shaped lithium battery (CR2450) only.

* Make sure to slide the battery sideways and take out the battery. Otherwise, the circuit board may be damaged.

* Put the battery in the specified direction. Setting it in wrong direction may cause a failure.

* The coin shaped lithium battery has the positive and negative terminals. Before setting the battery, be sure to check the direction of terminals.

10 Optional Accessories

(1) Connecting cable

ATGE → PC

Part No.384

Refer to chapter 7. External output specifications.



(2) Torque gauge calibration device

ATGTCL24CN

Components: Calibration device (main body),

calibration pulley x 2, calibration wire x 3,

Scale pan (5g, 100g).

Combination weights are sold separately. (WS-TCL2)



(3) Calibration adapter for ATGE-G Part No.806

For calibration of ATGE-G, the calibration device (ATGTCL24CN) and the calibration adapter (Catalog No.806) are needed.



(4) Plastic chuck

Part No.322



(5) ATGE-G Measurement plate

Part No.808

It is designed for ATGE-G to set on.

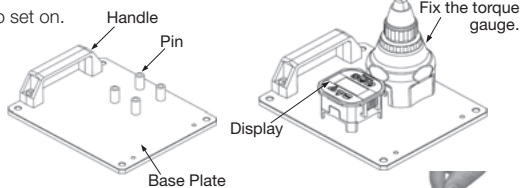

(6) Table Attachment

Part No.800

4 poles are designed to clamp objects of any shape.

Chucking diameter $\phi 10$ - $\phi 58$



(7) Adapter for USB connector BA-5

This adapter can be used when using external power supply. Use it with USB connecting cable No.384 (Option). To change to external power supply, the dip switch inside ATGE-G needs to be changed.

Specification: Input Voltage AC100-240V 50/60Hz

Output Voltage DC5V 0.5A, Output terminal USB

A-type (female)



11 How to Use the USB Adapter

- (1) Use the USB connecting cable. (Part No.384)
- (2) Slide open the battery cover on the back of the display.

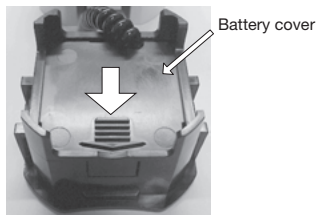

- (3) Set the dip switch to "USB" position with a slotted screwdriver.
 - * Do not apply excessive force to the dip switch not to damage it.

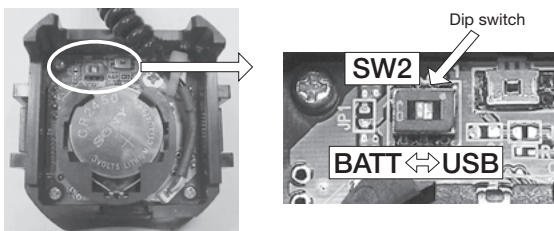

- (4) Connect USB cable (A-type female) to USB adapter (A-type male).

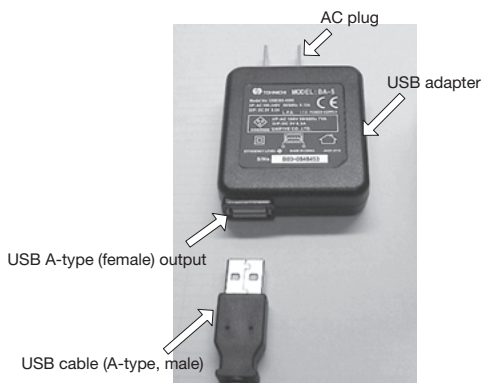

- (5) Connect USB cable B-type (female) to USB connector (male) on Display part.

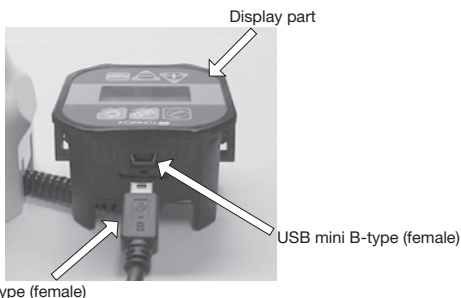

- (6) ATGE turns ON as you plug AC adapter plug to power source.
LCD display shows as follows.

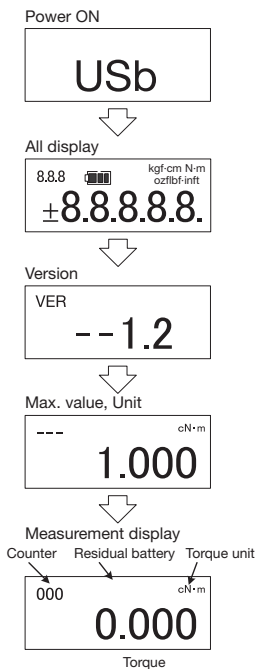

- (7) If selected " BATT": Enables auto power off and residual battery indicator functions.
If selected "USB" : Disables auto power off and residual battery indicator functions.

12 Specifications

Specifications

Accuracy $\pm 2\% + 1$ digit

Model	Torque Range							
	cN·m		mN·m		gf·cm		ozf·in	
	Min.-Max.	1digit	Min.-Max.	1digit	Min.-Max.	1digit	Min.-Max.	1digit
ATGE05CN-G	0.1-0.5	0.001	1-5	0.01	10-50	0.1	0.15-0.7	0.001
ATGE1CN-G	0.2-1	0.001	2-10	0.01	20-100	0.1	0.3-1.4	0.001
ATGE2CN-G	0.4-2	0.002	4-20	0.02	40-200	0.2	0.6-2.8	0.002
ATGE5CN-G	1-5	0.005	10-50	0.05	100-500	0.5	1.5-7	0.005
ATGE10CN-G	2-10	0.01	20-100	0.1	200-1000	1	3-14	0.01
ATGE20CN-G	4-20	0.02	40-200	0.2	400-2000	2	6-28	0.02

Model	Chuck dia. mm	Dimensions (mm)		Weight (kg)
		Total length	Out. dia.	
ATGE05CN-G	ø1-6.5	Approx. 120	Approx. 67	0.305
ATGE1CN-G				
ATGE2CN-G				
ATGE5CN-G				
ATGE10CN-G				
ATGE20CN-G				

Standard accessories ATGE chuck: Chuck case (aluminum), 3-jaws (steel)

Common specifications

Direction	Clockwise and counterclockwise
Display	7 segments LCD display Counter value: 3 digits (character height 3mm) Torque value: 4 digits (character height 7mm), Unit, Battery remaining, measuring direction
Measurement Mode	PEAK/RUN
Data Memory	999 readings
Statistical Processing	Number of samples, maximum value, minimum value, mean value
Data Output	USB output (USB mini B terminal)
Power	Coin-shaped lithium battery (CR2450)
Continuous Operating Hours	Approx. 10 hours when using coin battery, Approx. 50 hours when using battery pack BP-C1
Other functions	Auto power off (3 min.), Auto Memory/Reset 0.5 to 5 seconds variable, Auto Zero adjustment, Battery remaining indicator (in 4 steps)
Operating Temperature Range	0 to 40 degree (Non condensing)
Accessories	Coin battery (CR2450), carrying case

Dimensions

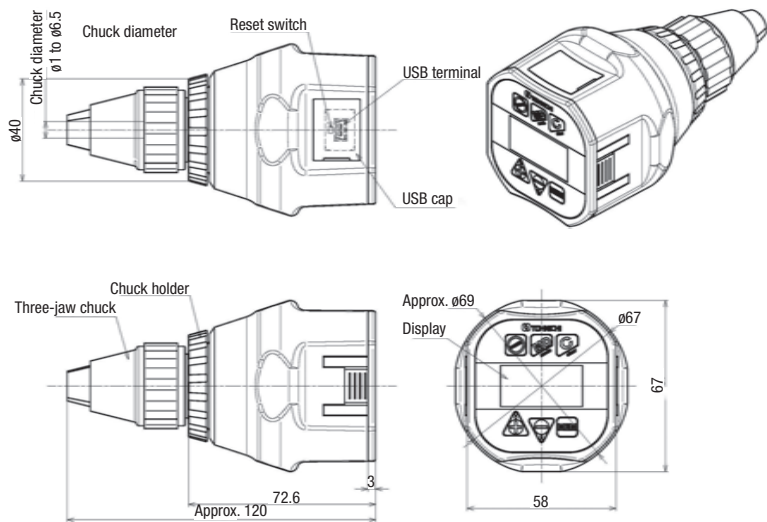

Designs and specifications are subject to change without notice.



Your Torque Partner

TOHNICHI

■ TOHNICHI MFG. CO., LTD.

TEL: +81-(0)3-3762-2455 FAX: +81-(0)3-3761-3852
2-12, Omori-kita, 2-Chome Ota-ku, Tokyo 143-0016, JAPAN
E-mail: overseas@tohnichi.co.jp
Website: <http://tohnichi.jp>

■ N. V. TOHNICHI EUROPE S. A.

TEL: +32-(0)16-606661 FAX: +32-(0)16-606675
Industrieweg 27 Boortmeerbeek, B-3190 Belgium
E-mail: tohnichi-europe@online.be
Website: <http://www.tohnichi.be>

■ TOHNICHI AMERICA CORP.

TEL: +1-(0)847-947-8560 FAX: +1-(0)847-947-8572
1303 Barclay Blvd. Buffalo Grove, IL 60089 U. S. A.
E-mail: iinquiry@tohnichi.com
Website: <http://tohnichi.com>

■ TOHNICHI AMERICA CORP. - Atlanta Office

TEL: +1-(0)678-423-5777 FAX: +1-(0)678-423-1333
4046 Hwy. 154 Suite 103 Newnan, GA 30265

■ TOHNICHI SHANGHAI MFG. CO., LTD.

东仁扭矩仪器(上海)有限公司
TEL: +86-(021)3407-4008 FAX: +86-(021)3407-4135
Rm. 5 No. 99 Nong1919, Du Hui Road.
Minhang, Shanghai. P.R. China