

MULTI FUNCTIONAL COUNT CHECKER MODEL Poka Patrol CNA-4mk3

OPERATING INSTRUCTION

Poka Patrol CNA-4mk3 Poka Patrol CNA-4mk3



To use this product properly and safely, please read this manual carefully before use. If you have any question about the product and its operations, please contact your nearest distributor or TOHNICHI MFG. CO., LTD.

Safety Precautions

To customers:

Before using this product, please read this operating instruction carefully to use it properly.

If you have any question, please contact your nearest distributor or TOHNICHI MFG. CO., LTD.

This operating instruction should be stored in a safe place.

Warning

Consider the ambient environment of the workplace.

Do not use the main body in the rain or a moist or wet place.

Failure to observe this may result in electric shock or smoking.

Keep the workplace well illuminated.

Working in a dark place may cause an accident.

Do not use the product in a place exposed to a combustible liquid or gas.

Failure to observe this may result in an explosion or a fire, causing an accident.

Use specified accessories and options.

Failure to observe this may cause an accident or an injury.

Caution

- Do not give vibrations or a shock to the product.
- Use the product only in the working environment mentioned in the operating instruction.
- Before use, carry out daily inspection to check the settings.
- Note that if the product is wetted with water or oil, it may result in trouble or burnout.
- Note that if the product is dropped or hit, it may result in damage and trouble.

If the product emits a foul odor or ignites during use, stop using it immediately, move this product to a safety place, and contact TOHNICHI MFG. CO., LTD.

Contents

1. Outline	3
2. Features	3
3. Components	4
4. Input and Output	7
4-1. I/O Terminal Block	7
4-2. I/O Circuits.....	9
4-3. Wiring	11
5. Useful Functions for 100% Usage of CNA-4mk3	12
5-1. Double Count Prevention Function	12
5-2. Automatic Reset Function	12
5-3. Automatic Judgment Function	13
5-4. NG Buzzer Sound Pattern Selective Function.....	13
5-5. Interval Warning Function	14
5-6. Usage Order ON/OFF Function	14
5-7. Torque Wrench Selection Signal Output Function	14
5-8. Work Sensor Input Function	14
6. Parameter Setting	15
6-1. Setting Procedure by Key Operation	15
6-2. Setting Procedure by PC	30
7. Usage Example	35
8. Optional Accessories	43
9. Troubleshooting	45
9-1. Self Check Mode	46
10. Specifications	49
11. Dimensions	50

1 Outline

Connecting any products having contact output, including TOHNICHI LS torque wrench (torque wrench with limit switch) QLLS, the Count Checker CNA-4mk3 is designed for judging OK/NG as to the tightening number of bolts to prevent them from being left untightened.

A wireless error-proofing (Pokayoke) torque system can be easily built by connecting the remote signal torque wrench FH256MC series receiver R-FH256 and multi-contact box I/O-FH256.

2 Features

- Low-cost introduction of an error-proofing (Pokayoke) torque system
Capable of easily building a variety of error-proofing (Pokayoke) torque systems at low cost owing to low-cost all-in-one specification.
- Multi-channel responsiveness
Capable of connecting up to 4 torque wrenches with limit switch and wireless torque wrenches.
- Simultaneous tightening
The use of dot-matrix LEDs (512 LEDs mounted) in the counter display section has improved expressivity to display the tightening number of bolts for 4 torque wrenches, thus allowing up to 4 workers to simultaneously engage in tightening operation.
- Arbitrary selection of 8 kinds of work settings
Capable of responding to a line where a variety of works are mixed owing to a select input terminal capable of arbitrary selection of up to 8 different work settings.
- Capable of setting the torque wrench usage order
Capable of responding to a variety of works because when using multiple torque wrenches for one work, you can select whether they should be randomly used without any order or whether they should be used according to the order.
- Torque wrench selection signal output
When using multiple torque wrenches, a wrong one may be selected for use. A tool selection error can be prevented by controlling a lamp, etc. mounted to a tool stand by this output.
- Work sensor input
By connecting a proximity sensor, etc. to this input, which detects presence of the work, NG judgment can be made even if the work has moved with bolts still left untightened.
- Interval warning function
Unless next tightening is done within a setting time halfway tightening, an alarm sounds to warn the worker, thus reducing an NG incidence rate.

- 4 patterns of NG buzzer

Since four patterns of NG buzzer sounds are available, the worker is not confused even if adjacently installed.

- High-volume buzzer (option)

The use of an optional high-volume buzzer allows you to hear a buzzer sound even in a very noisy work environment.

- Easy parameter setting

Various parameters can be easily set through USB communication from your PC by using special-purpose application software.

3 Components

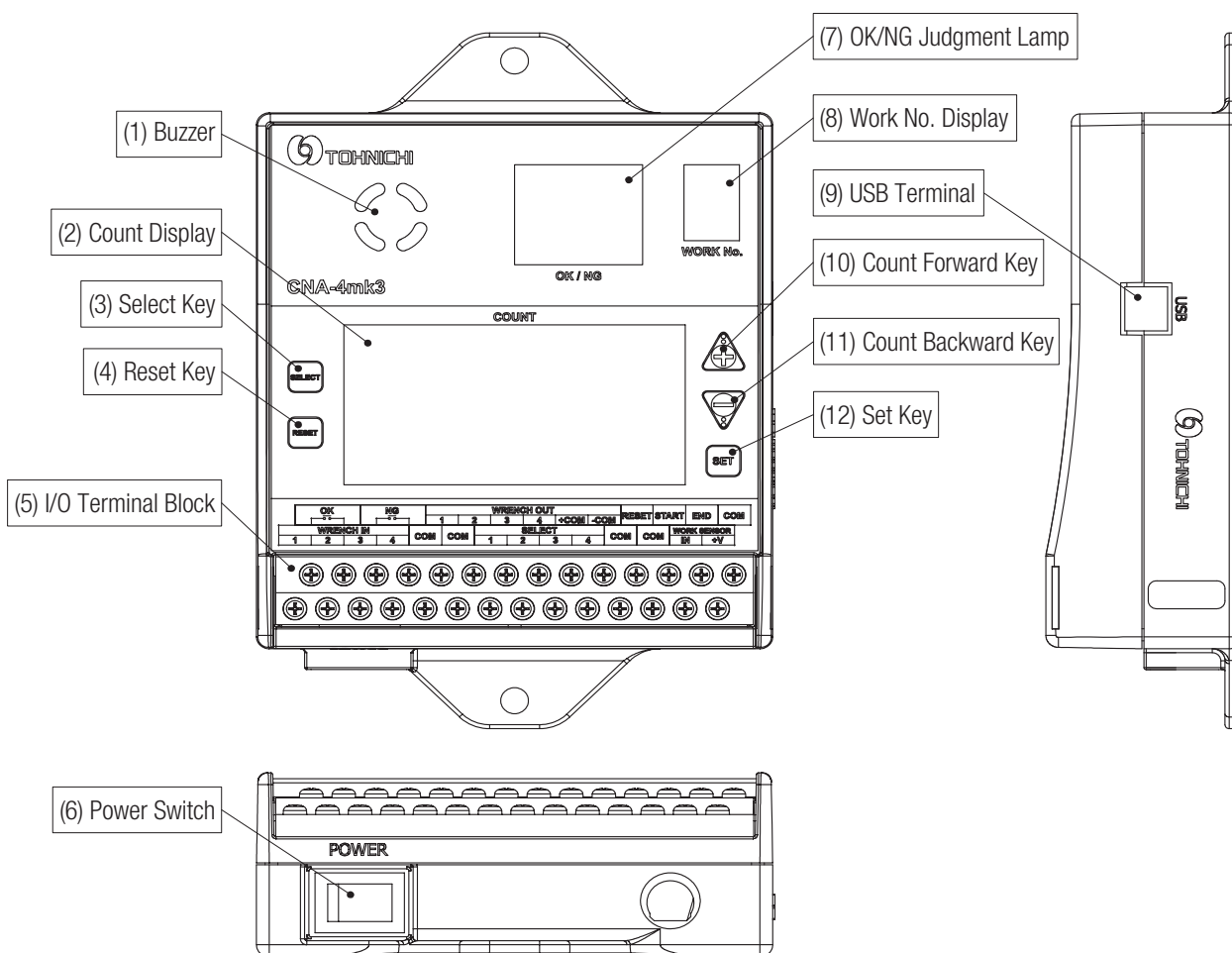

(1) Buzzer

The buzzer sounds when the OK/NG judgment result is NG. Four kinds of sound patterns are selectable.

(2) Count display

A selected work No. setting value is displayed and counted down on each count input.

[Description of the count display]

■ When the usage order setting is OFF

- Display example when using one torque wrench

Selected torque wrench No. is indicated with • (dot) as shown below.

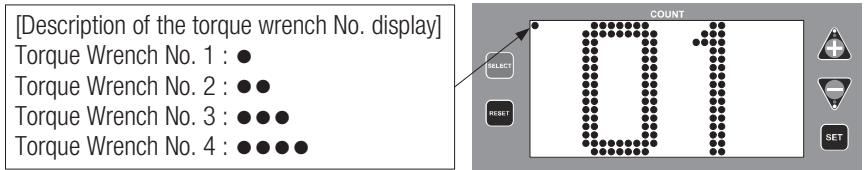

- Display example when using two torque wrenches

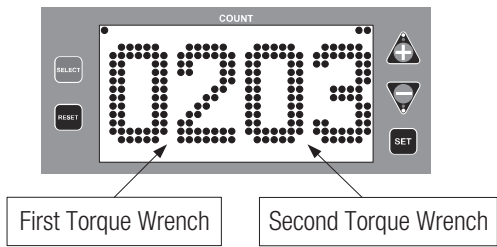

- Display example when using three torque wrenches

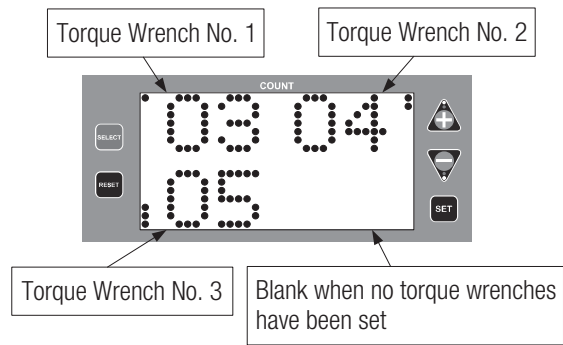

- Display example when using four torque wrenches

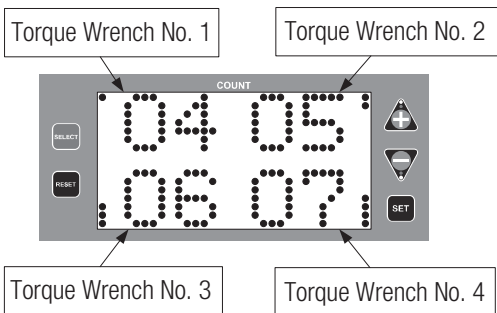

■ When the usage order setting is ON

- Display example when the usage order number setting is the first torque wrench = torque wrench No. 1 and the second one = torque wrench No. 3

Once tightening by the first torque wrench is completed, the next torque wrench is picked up after automatic resetting.

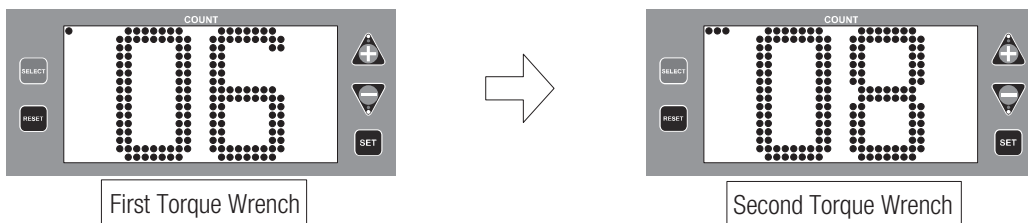

■ When the overcount setting is NG

When the overcount setting is NG and a count greater than the set tightening number of bolts is input, a negative value (-1 to -9) appears blinking.

- Display example when one torque wrench is displayed
- Display example when three torque wrenches are displayed

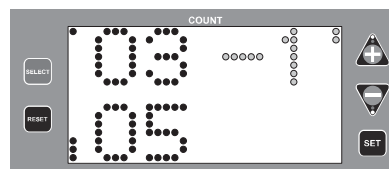
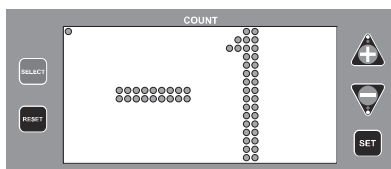

(3) Select key

Used for selecting the work Nos. 1 to 8. Every time this key is pressed, the work No. switches from 1 to 2, 3, ... 8, and back to 1.

(4) Reset key

Used for initializing the count display, and turning off the OK/NG judgment lamp and output. Press this key to initialize the count display to the set tightening number of bolts of the selected work No. and turn off the OK/NG judgment lamp and output.

(5) I/O terminal block

Designed for inputting count, work No. selection, reset, operation start/end and work sensor signals, and outputting OK/NG judgment result and torque wrench selection signals.

(6) Power switch

Used for turning on/off the power for the main body.

(7) OK/NG judgment lamp

Turned on/blinks in blue or red, corresponding to the OK/NG judgment result.

OK: Turned on in blue.

NG: Turned on or blinks in red (three kinds of blinking patterns selectable).

(8) Work No. display

Displays the selected work Nos. 1 to 8.

(9) USB terminal

Used for setting the parameters with special-purpose application software.

(10) Count forward key (▲ key)

Used for setting the parameters.

(11) Count backward key (▼ key)

Used for setting the parameters.

(12) Set key

Used for setting the parameters.

4 Input and Output

4-1. I/O Terminal Block

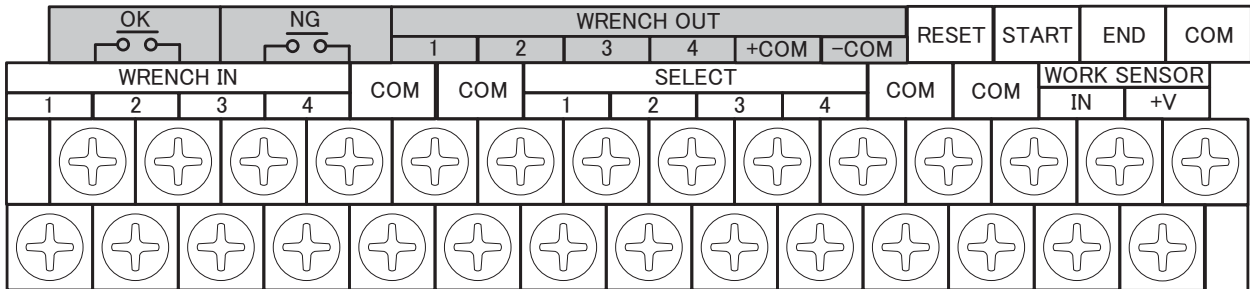

[Input terminals]

- WRENCH IN input terminal

Count signal input terminal. Connect one of two signal lines of the LS torque wrench to this terminal and the other one to the COM terminal. Every time the LS torque wrench is activated, the display is counted down.

- SELECT input terminal

Input terminal for selecting a work No. Connect it to a push button switch or PLC (relay contact output) and short-circuit with the COM terminal (pulse input of 0.1 second or more) in combination listed in the table below. This allows selection of your desired work No.

Work No.	Combination with SELECT Terminal
1	Short-circuit SELECT1 and COM.
2	Short-circuit SELECT2 and COM.
3	Short-circuit SELECT3 and COM.
4	Short-circuit SELECT4 and COM.
5	Short-circuit SELECT1, SELECT2 and COM at the same time.
6	Short-circuit SELECT1, SELECT3 and COM at the same time.
7	Short-circuit SELECT1, SELECT4 and COM at the same time.
8	Short-circuit SELECT2, SELECT3 and COM at the same time.

- WORK SENSOR input terminal

Connect a limit switch or proximity sensor to this input terminal. The presence of work is detected, and if the work is moved with some bolts left untightened, it is judged NG.

- START input terminal

Operation start signal input terminal. Connect it to a push button switch or PLC (relay contact output), short-circuit with the COM terminal (pulse input of 0.1 second or more) to start operation, thus starting the automatic judgment timers 1 and 2 to count.

- END input terminal

Operation end signal input terminal. Connect it to a push button switch or PLC (relay contact output), short-circuit with the COM terminal (pulse input of 0.1 second or more) to end operation, thus making OK/NG judgment based on the remaining count at that point.

- RESET input terminal

Input terminal for initializing the count display and turning off the OK/NG judgment lamp and output. Connect it to a push button switch or PLC (relay contact output), short-circuit with the COM terminal (pulse input of 0.1 second or more), thus initializing the count display to the set tightening number of bolts for the selected work No. without pressing the Reset switch disposed on the main body, and turning off the OK/NG judgment lamp and output.

When the usage order setting is ON and the second or later torque wrench is being used, this input initializes to the set tightening number of bolts for the torque wrench in use. Repeating this input initializes to the set tightening number of bolts for the first torque wrench of the selected work No.

When the usage order setting is OFF and multiple torque wrenches are used, you can initialize the set tightening number of bolts for the torque wrenches individually judged NG by combining with the SELECT terminal as listed in the table below and turn off the NG lamp and NG output.

(1) When using two torque wrenches

Torque Wrench	Combination with SELECT Terminal
First	Short-circuit RESET, SELECT1 and COM at the same time.
Second	Short-circuit RESET, SELECT2 and COM at the same time.

(2) When using three or four torque wrenches

Torque Wrench No.	Combination with SELECT Terminal
1	Short-circuit RESET, SELECT1 and COM at the same time.
2	Short-circuit RESET, SELECT2 and COM at the same time.
3	Short-circuit RESET, SELECT3 and COM at the same time.
4	Short-circuit RESET, SELECT4 and COM at the same time.

[Output terminals]

- OK output terminal

In case of preset judgment, OK judgment results when count input reaches the set tightening number of bolts, and a relay contact is turned on to output to this terminal.

In case of end input judgment or automatic judgment, output is made when a signal is input to the END input terminal while count input has reached the set tightening number of bolts, and

when the automatic judgment timer reaches “0 (zero)”.

- NG output terminal

When a signal is input to the END input terminal while count input has exceeded the set tightening number of bolts (when the overcount setting is NG) or has not reached it, and when the automatic judgment timer reaches “0 (zero)”, NG judgment results and a relay contact is turned on to output to this terminal.

- WRENCH OUT output terminal

WRENCH OUT1 to WRENCH OUT4 corresponding to the selected torque wrench No. 1 to No. 4 is turned on. This output prevents a tool selection error by controlling a tool lamp, etc. mounted to a tool stand.

4-2. I/O Circuits

[Input circuits]

- WRENCH IN, SELECT, RESET, START and END input terminals

Connect no-voltage contact switches such as an LS torque wrench, push button switch, and relay to these input terminals to use. * Never connect an external power supply. It may cause a trouble.

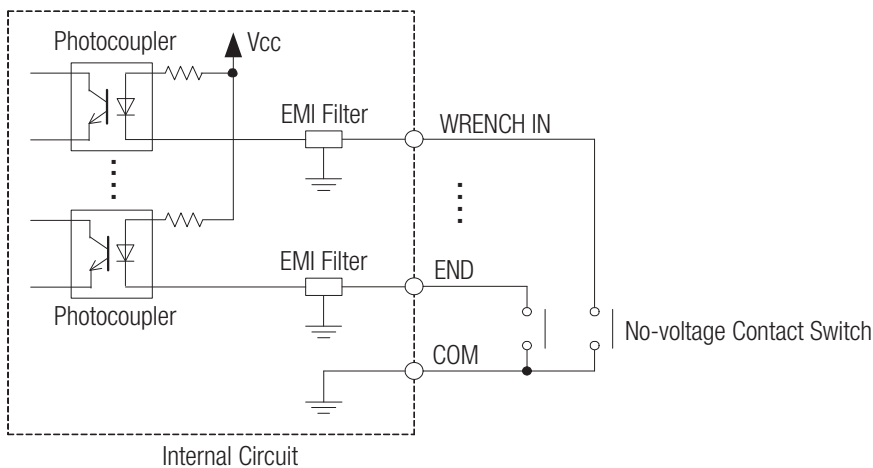

- WORK SENSOR input terminal

This input terminal is photocopier isolated input and requires the external power supply. Connect an NPN output type proximity sensor, etc. and the external power supply to use.

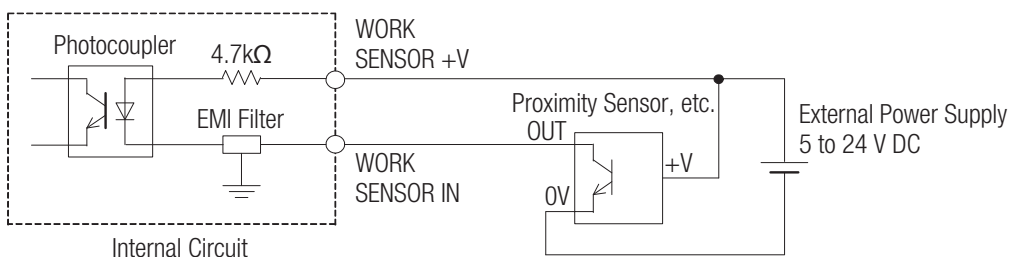

[Output circuits]

- WRENCH OUT output terminal

This output terminal is photocoupler isolated open collector output and requires the external power supply. Output current rating is 100 mA per terminal at maximum.

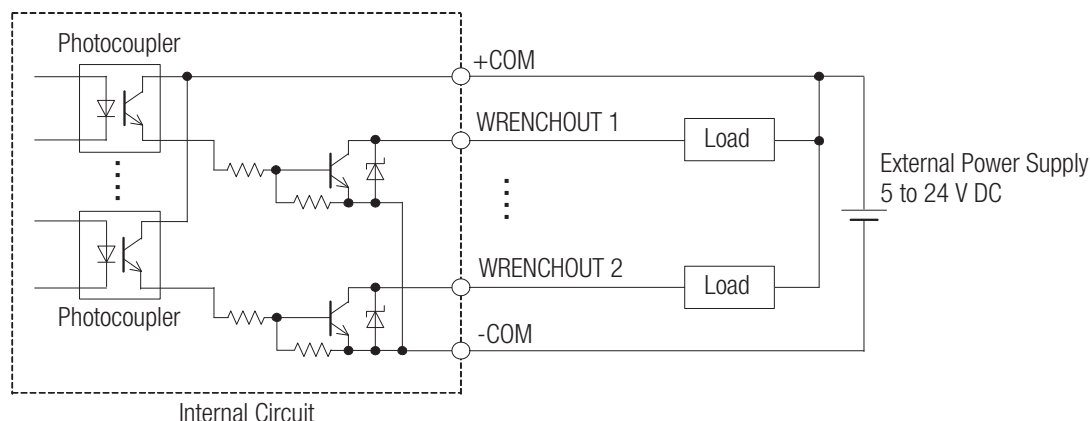

- OK and NG output terminals

This output terminal is no-voltage output of relay contact.

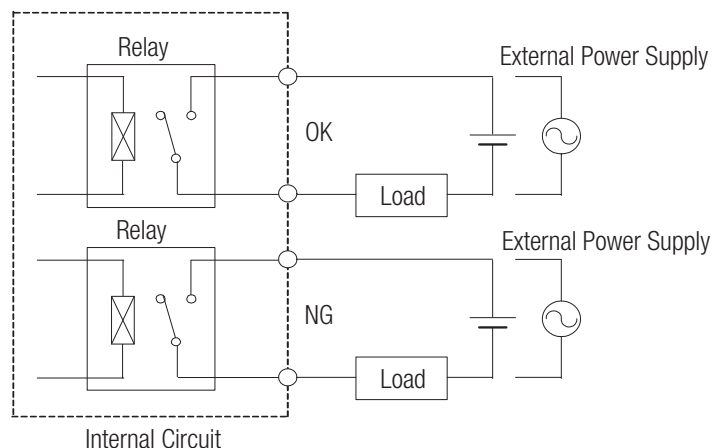

* Precaution for using relay contact output

(1) Use the load within the rating. (Relay output rating: 30 V DC, 1 A, 125 V AC, 0.3 A)

(2) The rated contact capacity above is based on a resistance load. There may be a large difference between a steady current and an inrush current depending on the type of load. The following table provides the typical load versus inrush current.

Type of Load	Inrush Current
Resistance load	Steady current x 1
Solenoid load	Steady current x 10 to 20
Motor load	Steady current x 5 to 10
Incandescent bulb load	Steady current x 10 to 15
Mercury lamp load	Steady current x Approx. 3
Sodium vapor lamp load	Steady current x 1 to 3
Condenser load	Steady current x 20 to 40
Transformer load	Steady current x 5 to 15

(3) When opening/closing an induction load, a back electric voltage occurs, damages a contact greatly, thus shortening a service life considerably. Accordingly, a contact protection circuit is required. The following table lists typical contact protection circuits.

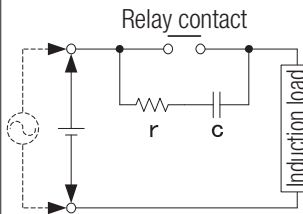
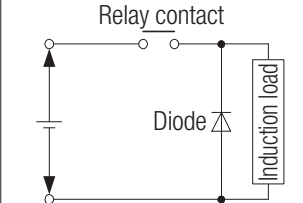
Circuit Example	Applicable Power		Features, etc.	Element Selection Method
	AC	DC		
<p>CR Type</p> 	△*	○	<p>When the load is a timer, a leak current runs through "c" and "r", causing malfunctioning. * When using with the AC voltage, the impedance of the load should be greatly lower than that of "c" and "r".</p> <p>When the load is a relay, solenoid, etc., a recovery time becomes longer. It is effective to connect between the loads when a supply voltage is 24 or 48 V, and between the contacts when it is 100 to 200 V, respectively.</p>	<p>The criteria of "c" and "r" are as follows. c: 0.5 to 1 (μF) with respect to the contact current of 1 A. r: 0.5 to 1 (Ω) with respect to the contact voltage of 1 V. They are not always consistent depending on the variation of the load nature and relay characteristics. Considering that "c" controls contact opening discharge and "r" controls the current control at next input time, confirm in an experiment. The withstand voltage of "c" should be generally 200 to 300 V. In case of an AC circuit, use an AC condenser (no polarities).</p>
<p>Diode Type</p> 	×	○	<p>Energy stored in a coil is run to the coil in the form of a current by a parallel diode and consumed as Joule heat for the resistance of the induction load. This type takes a longer recovery time than the CR type.</p>	<p>The diode should have a peak inverse voltage more than 10 times higher than a circuit voltage and a forward current higher than a load current. When an electronic circuit has not so high a circuit voltage, the peak inverse voltage about a couple of times higher than the supply voltage will do.</p>

4-3. Wiring

- (1) Prior to wiring work, confirm that the product and other devices are turned off.
- (2) Use the crimping terminals of the following size. Up to two crimping terminals can be attached to one terminal. * The tightening torque of terminal block screws is $T = 0.5 \text{ N}\cdot\text{m}$.

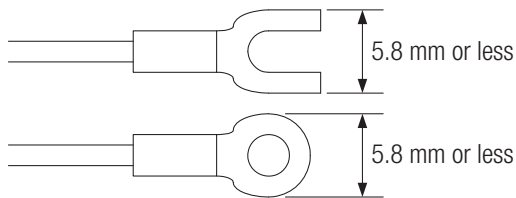

5 Useful Functions for 100% Usage of CNA-4mk3

5-1. Double Count Prevention Function

Even if the microswitch, etc. of the device connected to WRENCH IN chatters, only the first time can be counted depending on the setting time of a double count prevention timer (in steps of 0.1 second from 0.1 to 10 seconds). Even if the worker tightens twice, only the first time can be counted.

[Setting example]

Double count prevention timer	0.5 second
-------------------------------	------------

[Timing chart]

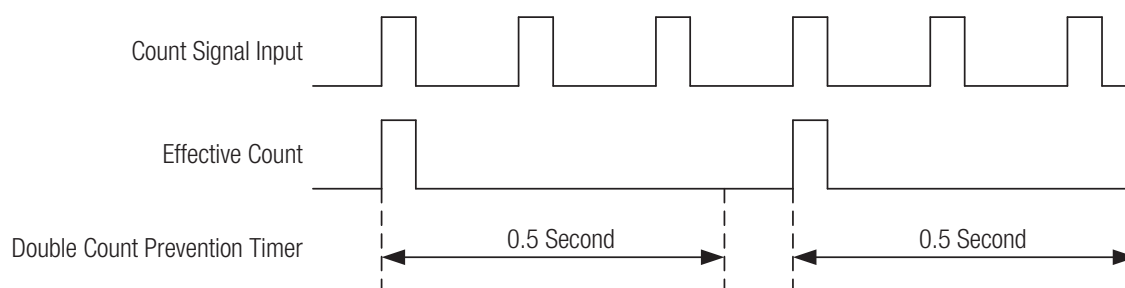

5-2. Automatic Reset Function

When the judgment result is OK and the setting time of the automatic reset timers 1 and 2 (in steps of 1 second from 0 to 60 seconds) has passed, this function initializes the count display to the set tightening number of bolts for the selected work No. and turns off the OK/NG judgment lamp and output.

When the usage order setting is ON and there is the next torque wrench, control shifts to the set tightening number of bolts for the next torque wrench. (When the setting time of these timers is 0 second or the OK output pattern setting is OU1, however, the setting time is fixed at 2 seconds except the last torque wrench.)

[Setting example]

Tightening number of bolts	3 pcs.
Automatic reset timers	2 seconds

[Timing chart]

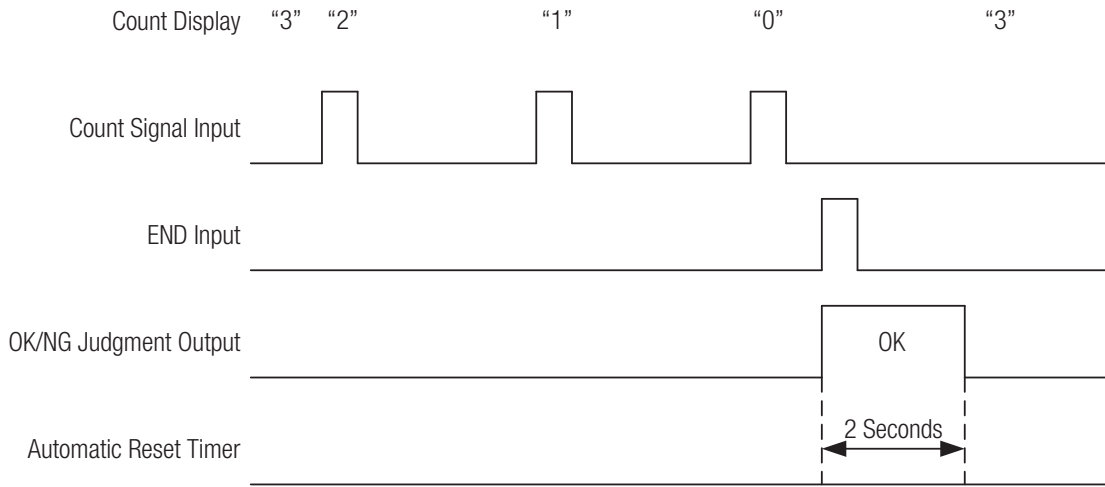

5-3. Automatic Judgment Function

The automatic judgment timers 1 and 2 (in steps of 1 second from 1 to 300 seconds) start counting after START input is made or the first count signal is input, and OK/NG judgment is made with the remaining count upon lapse of the setting time.

[Setting example]

Tightening number of bolts	3 pcs.
Automatic judgment timers	6 seconds

[Timing chart]

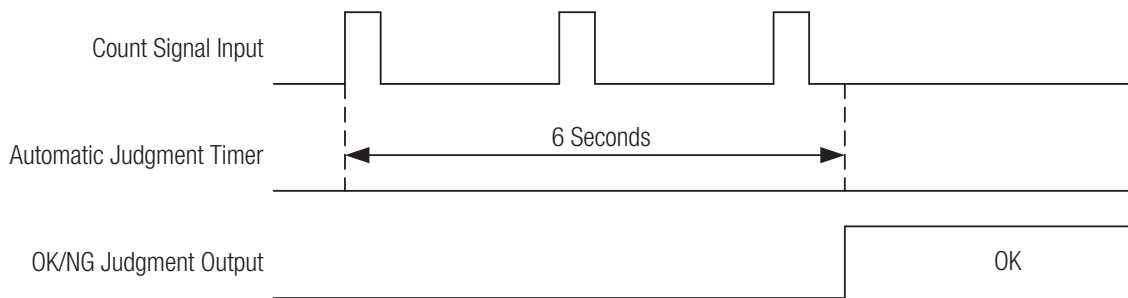

5-4. NG Buzzer Sound Pattern Selective Function

Since the below-listed four patterns of NG buzzer sounds are available, the worker is not confused even if adjacently installed.

Setting	Sound Pattern
BZ1	Long beep
BZ2	Double long beep
BZ3	Long beep followed by double short beep
BZ4	Long beep followed by triple short beep

5-5. Interval Warning Function

Unless next tightening is done within a setting time halfway tightening, an alarm sounds to warn the worker, thus reducing an NG incidence rate.

[Setting example]

Tightening number of bolts	4 pcs.
Interval warning timer	5 seconds

[Timing chart]

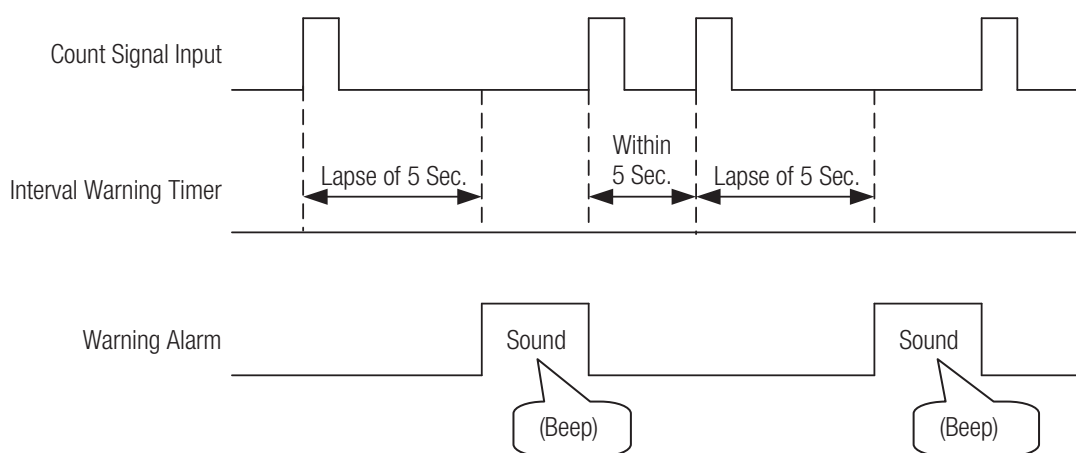

5-6. Usage Order ON/OFF Function

This function allows you to respond to a variety of works because when using multiple torque wrenches for one work, you can select whether they should be randomly used without any order or whether they should be used according to the order.

5-7. Torque Wrench Selection Signal Output Function

When using multiple torque wrenches, a wrong one may be selected for use. A tool selection error can be prevented by controlling a lamp, etc. mounted to a tool stand by this output.

5-8. Work Sensor Input Function

By connecting a proximity sensor, etc. to this input, which detects presence of the work, NG judgment can be made even if the work has moved with bolts still left untightened.

6 Parameter Setting

6-1. Setting Procedure by Key Operation

(1) Pressing the ▲ key and SET key, turn on the main body. “SET” appears in the display section.

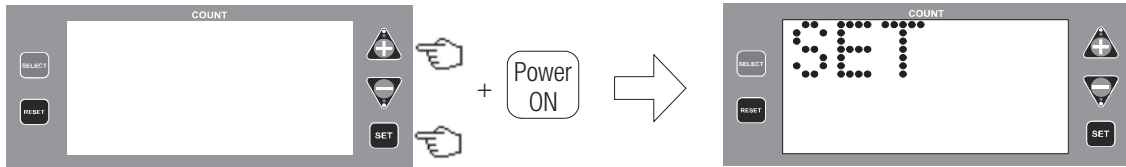

(2) Hold down the SET key for 2 seconds. Tightening number of bolts “BQ” appears.

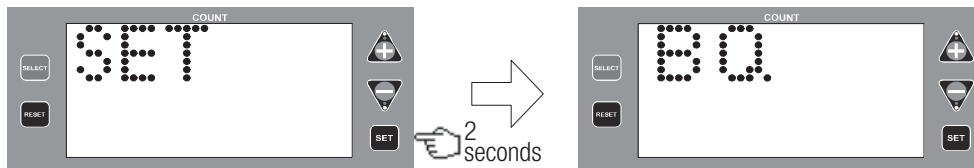

(3) Press the ▲ or ▼ key to select the item you want to set.

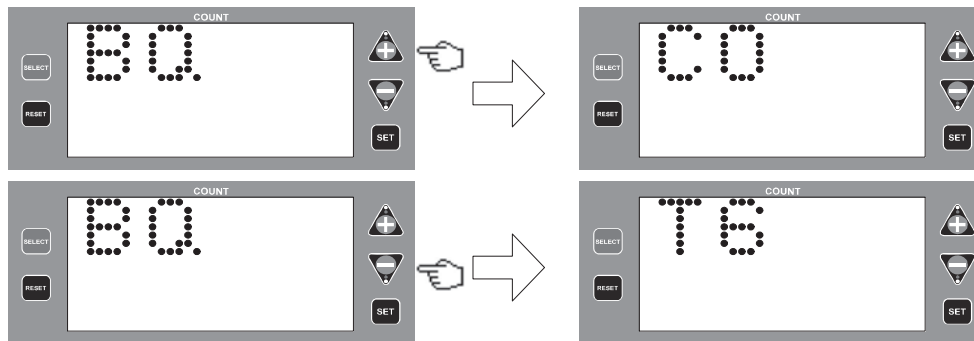

(4) Turn off power when parameter setting is completed.

[Setting items]

Display	Setting item	Setting Data	Factory Setting				Page
			Torque Wrench No.				
			1	2	3	4	
BQ	Tightening number of bolts	0 to 99	1	0	0	0	P16
CO	Overcount	NG, OK	NG	NG	NG	NG	P17
T1	Double count prevention timer	0.1 to 10.0 sec. (in steps of 0.1 sec.)	0.1	0.1	0.1	0.1	P18
T2	Automatic reset timer 1	0 to 60 sec. (in steps of 1 sec.)	0				P19
JG	Judgment mode	JG1 to JG4	JG1				P20
T3	Automatic judgment timer 1	1 to 300 sec. (in steps of 1 sec.)	1				P21
BZ	NG buzzer sound pattern	BZ1 to BZ4	BZ1				P22
PR	Usage order	OFF, ON	OFF				P23
UP	Usage order No.	No. 1 to No. 4	No.1	No.2	No.3	No.4	P24
NE	Next torque wrench alarm	NE1 to NE3	NE1				P25
T4	Interval timer	0 to 99 sec (in steps of 1 sec.)	0	0	0	0	P26
OU	OK output pattern	OU1, OU2	OU1				P27
T5	Automatic reset timer 2	0 to 60 seconds (in steps of 1 sec.)	0	0	0	0	P28
T6	Automatic judgment timer 2	1 to 300 sec. (in steps of 1 sec.)	1	1	1	1	P29

• Tightening number of bolts setting

(1) Press the SET key. The tightening number of bolts appears for each torque wrench No. of the work No. 1, alternately displaying the currently selected torque wrench No. 1 and “BQ”.

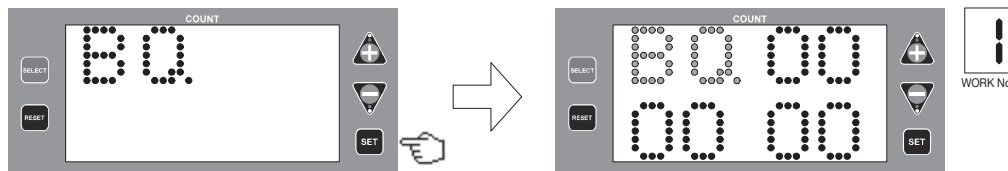

[Description of the setting data]
 Set the tightening number of bolts, 0 to 99; set “0” for the unused torque wrench.
 Factory setting: Torque wrenches No. 1, 2, 3 and 4 = 1, 0, 0 and 0 pc.

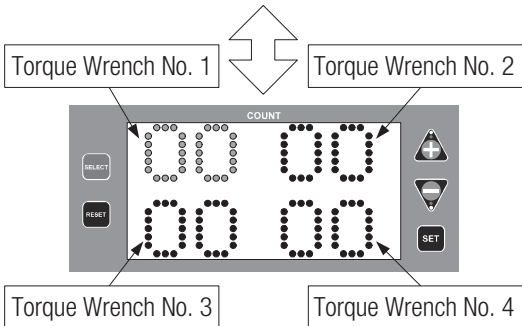

(2) Press the ▲ or ▼ key to set the tightening number of bolts.

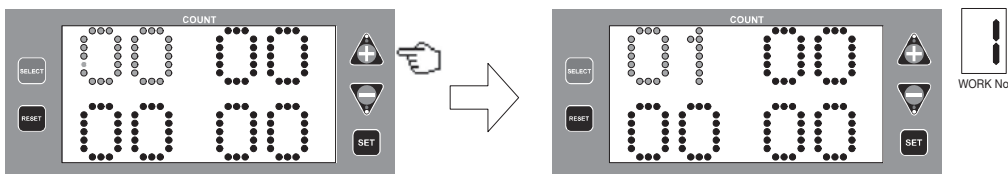

(3) Pressing the SELECT key to change the torque wrench No. from 1 to 2, 3 and 4, set the tightening number of bolts for each torque wrench No. in the same manner as mentioned above.

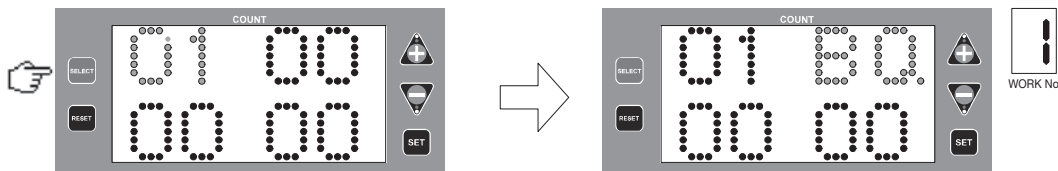

(4) Once you are finished with setting for each torque wrench No. of the work No. 1, press the SET key. The setting of each torque wrench is entered and control goes to the next work No. 2. Set the data for each work No. in the same manner.

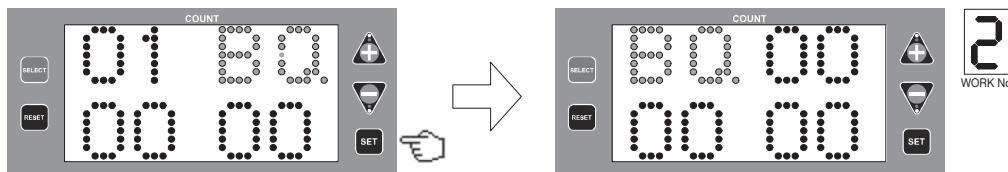

Once the setting of the work No. 8 is entered, the overcount setting screen appears.

(5) To return to the setting item selection screen halfway setting, press the RESET switch.

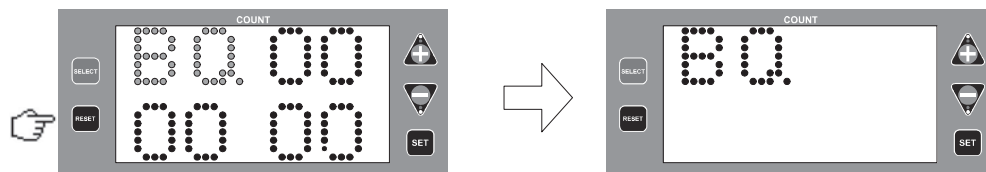

• Overcount setting

- (1) Press the SET key. The overcount setting appears for each torque wrench No. of the work No. 1, alternately displaying the currently selected torque wrench No. 1 and “CO”.

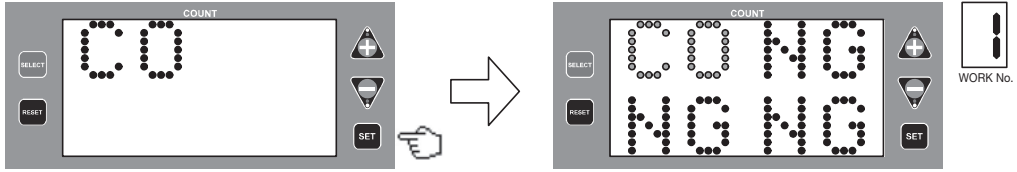

[Description of the setting data]
 NG: NG judgment results when more bolts have been tightened than the set tightening number of bolts. (This function is enabled only when the usage order setting is ON and entire tightening operation ends after preset judgment.)
 OK: OK judgment results even if more bolts have been tightened than the set tightening number of bolts.
 Factory setting: NG

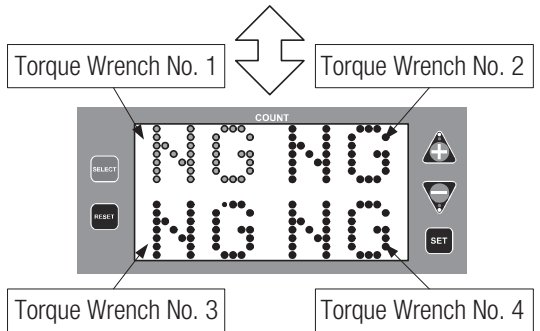

- (2) Press the ▲ or ▼ key to select OK/NG.

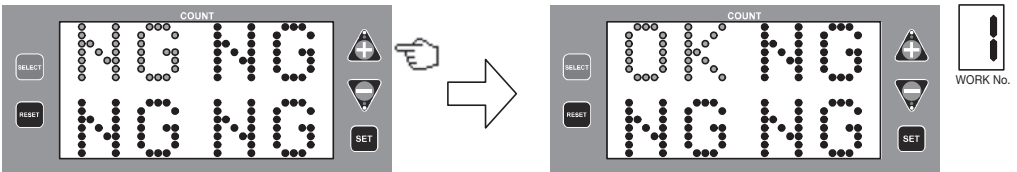

- (3) Pressing the SELECT key to change the torque wrench No. from 1 to 2, 3 and 4, select OK/NG for each torque wrench No. in the same manner as mentioned above.

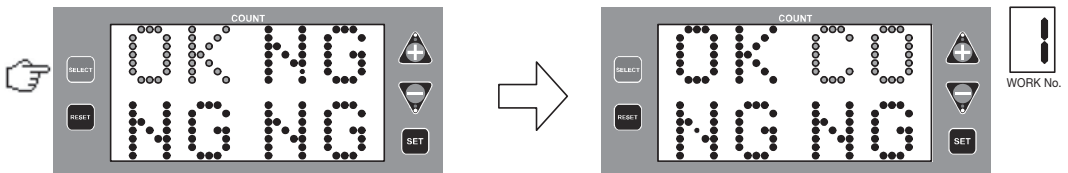

- (4) Once you are finished with setting for each torque wrench No. of the work No. 1, press the SET key. The setting of each torque wrench is entered and control goes to the next work No. 2. Set the data for each work No. in the same manner.

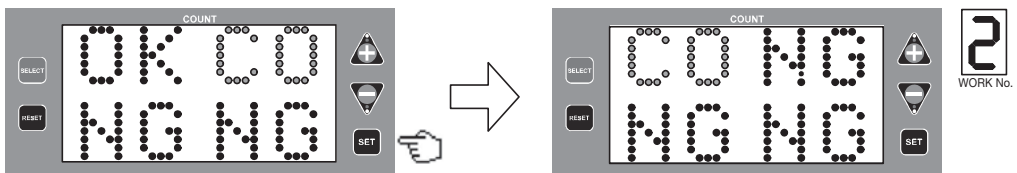

Once the setting of the work No. 8 is entered, the double count prevention timer setting screen appears.

- (5) To return to the setting item selection screen halfway setting, press the RESET switch.

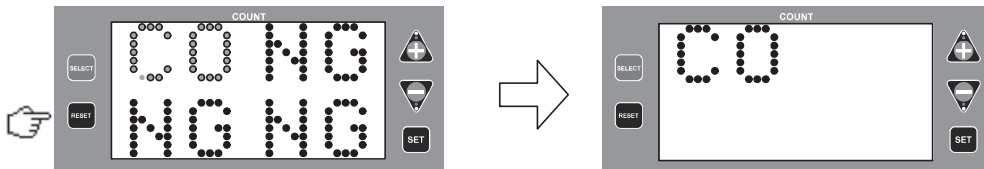

• Double count prevention timer setting

(1) Press the SET key. The double count prevention timer setting appears for each torque wrench No. of the work No. 1, alternately displaying the currently selected torque wrench No. 1 and “T1”.

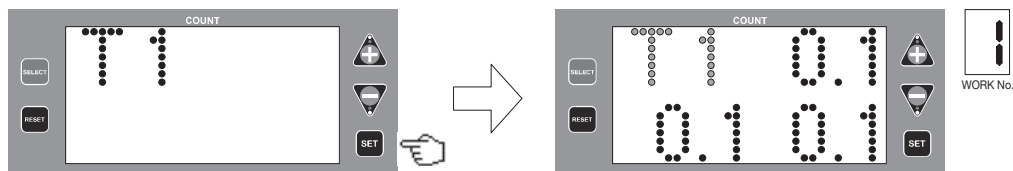

[Description of the setting data]
 Set the double count prevention timer within a range of 0.1 to 10.0 seconds (in steps of 0.1 second).
 For details, see page XX.
 Factory setting: 0.1 second

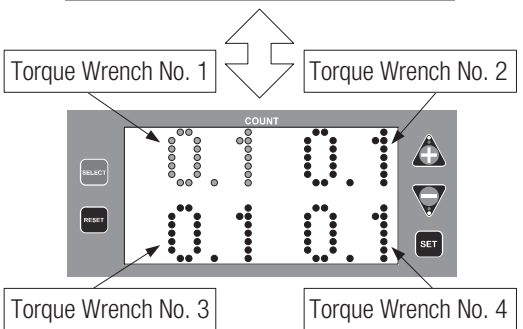

(2) Press the ▲ or ▼ key to set the time (seconds).

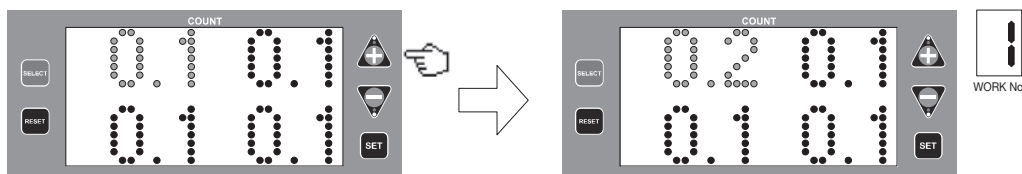

(3) Pressing the SELECT key to change the torque wrench No. from 1 to 2, 3 and 4, set the time (seconds) for each torque wrench No. in the same manner as mentioned above.

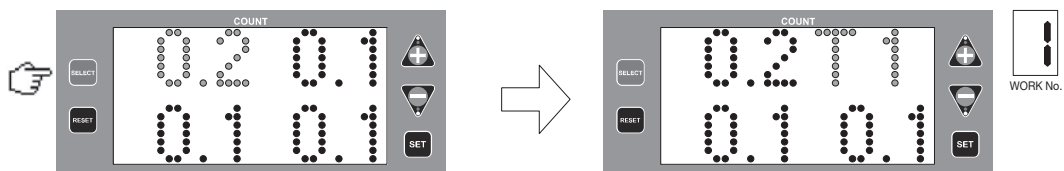

(4) Once you are finished with setting for each torque wrench No. of the work No. 1, press the SET key. The setting of each torque wrench is entered and control goes to the next work No. 2. Set the data for each work No. in the same manner.

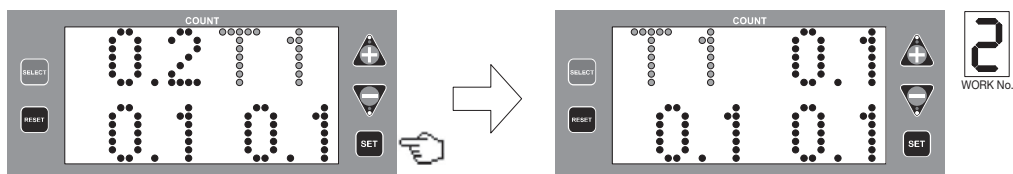

Once the setting of the work No. 8 is entered, the automatic reset timer 1 setting screen appears.

(5) To return to the setting item selection screen halfway setting, press the RESET switch.

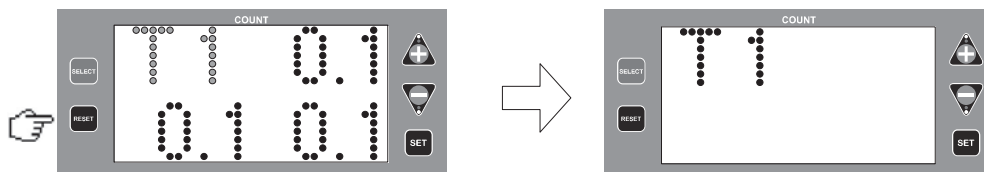

• Automatic reset timer 1 setting

(1) Press the SET key. The automatic reset timer 1 setting for the work No. 1 appears and alternates with "T2".

[Description of the setting data]
 Set the automatic reset timer 1 within a range of 0 to 60 seconds (in steps of 1 second).
 For details, see page 12.
 Factory setting: 0 second

(2) Press the ▲ or ▼ key to set the time (seconds).

(3) Once the time is set, press the SET key. The setting is entered and control goes to the next work No. 2. Set the data for each work No. in the same manner.

Once the setting of the work No. 8 is entered, the judgment mode setting screen appears.

(4) To return to the setting item selection screen halfway setting, press the RESET switch.

• Judgment mode setting

(1) Press the SET key. The judgment mode setting for the work No. 1 appears and alternates with “JG”.

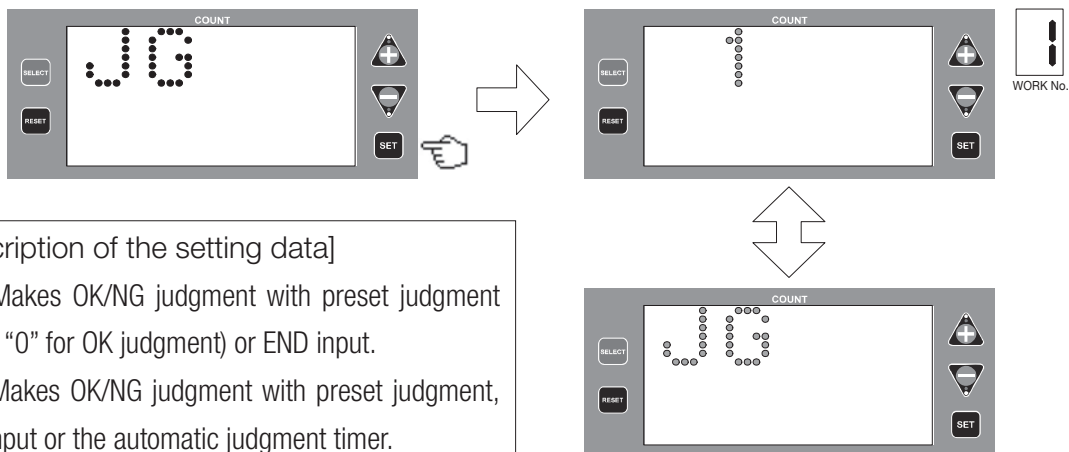

[Description of the setting data]
 JG1: Makes OK/NG judgment with preset judgment (count “0” for OK judgment) or END input.
 JG2: Makes OK/NG judgment with preset judgment, END input or the automatic judgment timer.
 JG3: Makes OK/NG judgment with the automatic judgment timer.
 JG4: Makes OK/NG judgment with END input.
 Factory setting: JG1

(2) Press the ▲ or ▼ key to select the judgment mode.

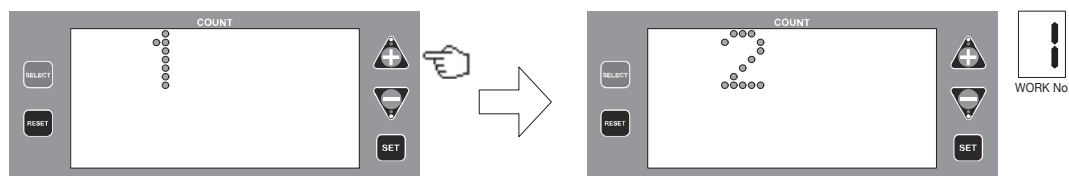

(3) Once selection is made, press the SET key. The setting is entered and control goes to the next work No. 2. Set the data for each work No. in the same manner.

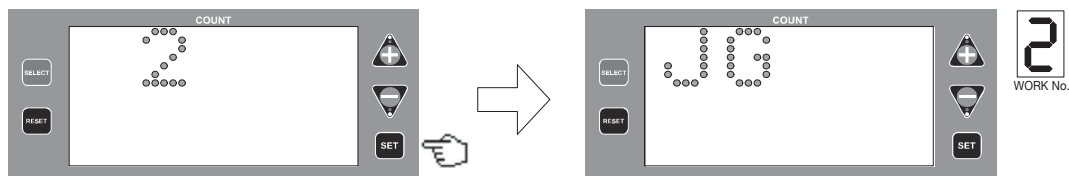

Once the setting of the work No. 8 is entered, the automatic judgment timer 1 setting screen appears.

(4) To return to the setting item selection screen halfway setting, press the RESET switch.

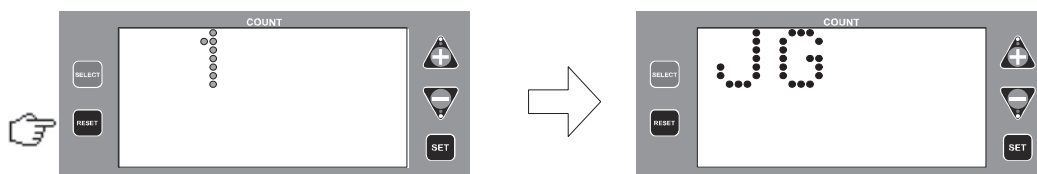

• Automatic judgment timer 1 setting

(1) Press the SET key. The automatic judgment timer 1 setting for the work No. 1 appears and alternates with “T3”.

[Description of the setting data]
 Set the automatic judgment timer 1 within a range of 1 to 300 seconds (in steps of 1 second).
 This function is enabled only when the judgment mode setting is JG2 or JG3.
 For details, see page 13.
 Factory setting: 1 second

(2) Press the ▲ or ▼ key to set the time (seconds).

(3) Once the time is set, press the SET key. The setting is entered and control goes to the next work No. 2. Set the data for each work No. in the same manner.

Once the setting of the work No. 8 is entered, the NG buzzer sound pattern setting screen appears.

(4) To return to the setting item selection screen halfway setting, press the RESET switch.

• NG buzzer sound pattern setting

(1) Press the SET key. The NG buzzer sound pattern setting for the work No. 1 appears and alternates with “BZ”.

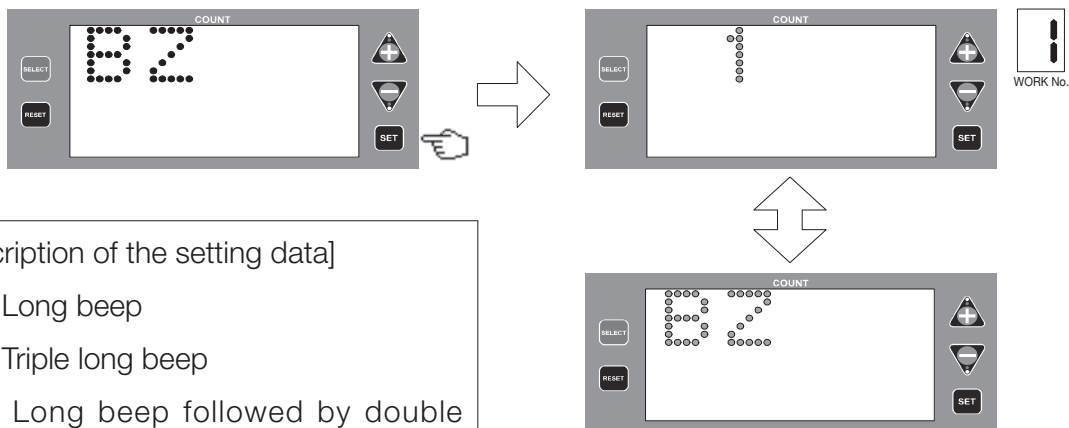

[Description of the setting data]
 BZ1: Long beep
 BZ2: Triple long beep
 BZ3: Long beep followed by double short beep
 BZ4: Long beep followed by triple short beep
 For details, see page 13.
 Factory setting: BZ1

(2) Press the ▲ or ▼ key to select the NG buzzer sound pattern.

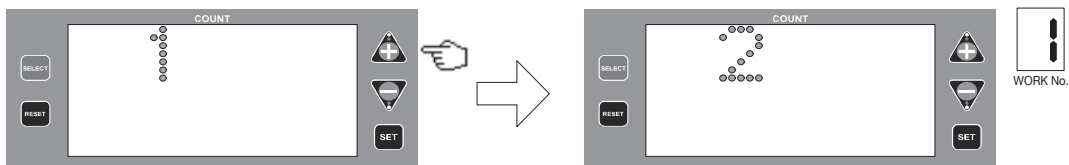

(3) Once selection is made, press the SET key. The setting is entered and control goes to the next work No. 2. Set the data for each work No. in the same manner.



Once the setting of the work No. 8 is entered, the usage order setting screen appears.

(4) To return to the setting item selection screen halfway setting, press the RESET switch.

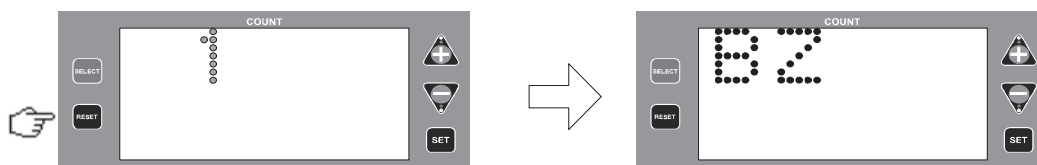

• Usage order setting

(1) Press the SET key. The usage order setting for the work No. 1 appears and alternates with "PR".

[Description of the setting data]

OFF: Select this in case of simultaneous tightening by multiple workers or when using torque wrenches randomly with no usage order.

ON: Select this when using the torque wrenches according to the usage order.

For details, see page 14.

Factory setting: OFF

(2) Press the ▲ or ▼ key to select ON/OFF.

(3) Once selection is made, press the SET key. The setting is entered and control goes to the next work No. 2. Set the data for each work No. in the same manner.

Once the setting of the work No. 8 is entered, the usage order No. setting screen appears.

(4) To return to the setting item selection screen halfway setting, press the RESET switch.

• Usage order No. setting

(1) Press the SET key. The usage order No. setting appears for each torque wrench No. of the work No. 1, alternately displaying the currently selected torque wrench No. 1 and “UP”.

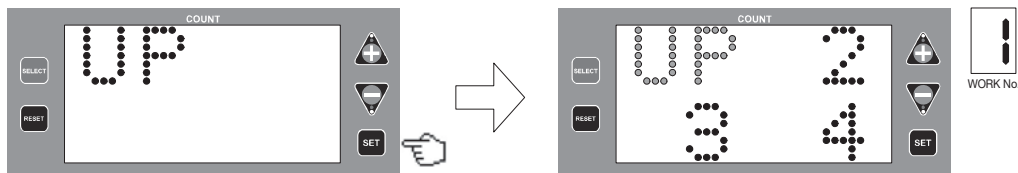

[Description of the setting data]
 Set the torque wrench usage order. This function is enabled only when the usage order setting is ON.
 Factory setting: Torque wrench No. 1, 2, 3 and 4 = 1, 2, 3 and 4

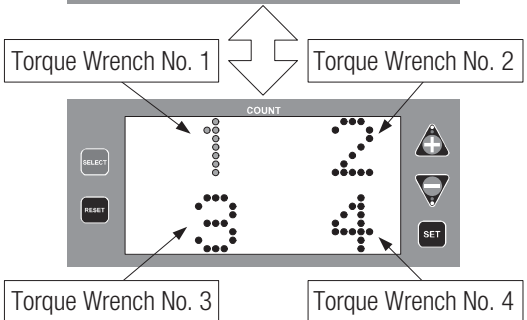

(2) Press the ▲ or ▼ key to set the torque wrench usage order, paying attention to the following.
 Note 1: Do not duplicate the usage order No.
 Note 2: Assign the torque wrench Nos. in the ascending order; set “1” for the unused (set tightening number of bolts = 0) torque wrench No..

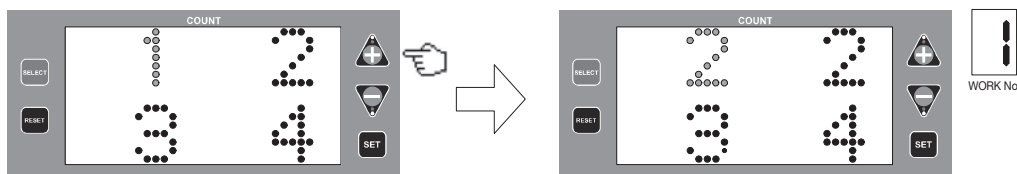

(3) Pressing the SELECT key to change the torque wrench No. from 1 to 2, 3 and 4, set the usage order No. for each torque wrench No. in the same manner as mentioned above.

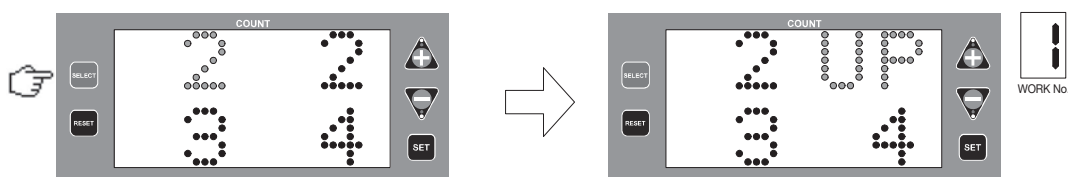

(4) Once you are finished with setting for each torque wrench No. of the work No. 1, press the SET key. The setting of each torque wrench is entered and control goes to the next work No. 2. Set the data for each work No. in the same manner.
 When the usage order No. is duplicated, an error results, disabling a data entry.

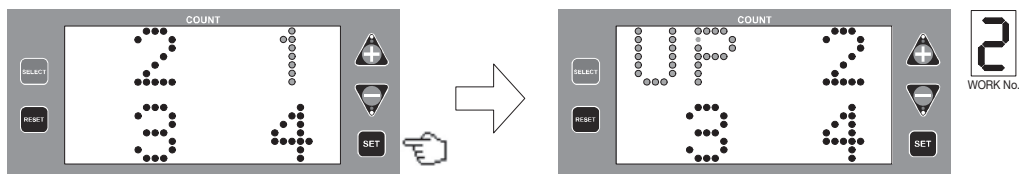

Once the setting of the work No. 8 is entered, the NEXT torque wrench alarm setting screen appears.

(5) To return to the setting item selection screen halfway setting, press the RESET switch.

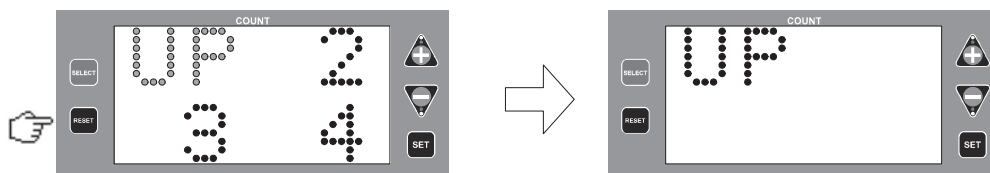

• NEXT torque wrench alarm setting

(1) Press the SET key. The NEXT torque wrench alarm setting for the work No. 1 appears and alternates with “NE”.

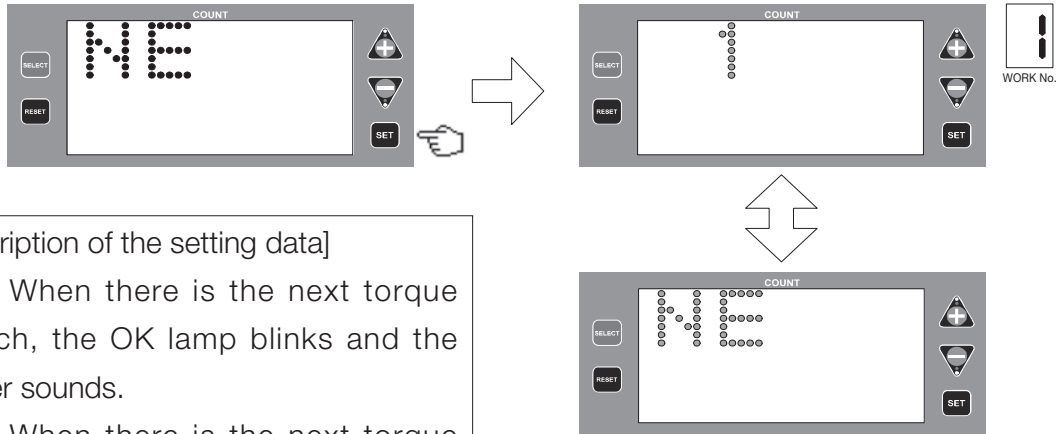

[Description of the setting data]
 NE1: When there is the next torque wrench, the OK lamp blinks and the buzzer sounds.
 NE2: When there is the next torque wrench, the OK lamp blinks.
 NE3: No alarm.
 This function is enabled only when the usage order setting is ON.
 Factory setting: NE1

(2) Press the ▲ or ▼ key to select NEXT torque wrench alarm.

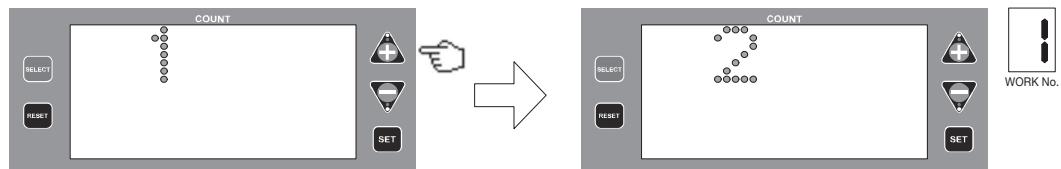

(3) Once selection is made, press the SET key. The setting is entered and control goes to the next work No. 2. Set the data for each work No. in the same manner.

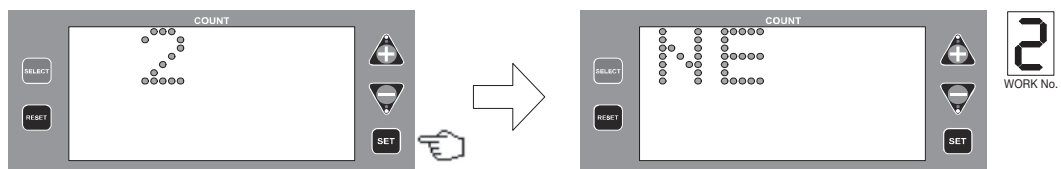

Once the setting of the work No. 8 is entered, the interval timer setting screen appears.

(4) To return to the setting item selection screen halfway setting, press the RESET switch.

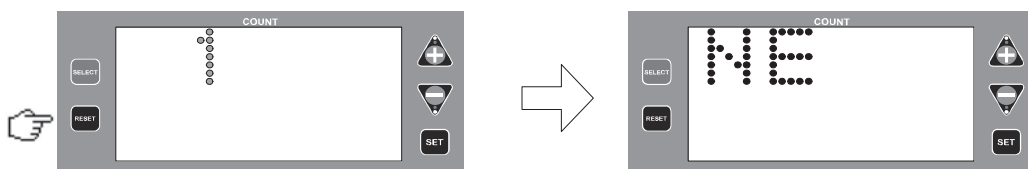

• Interval timer setting

(1) Press the SET key. The interval timer setting appears for each torque wrench No. of the work No. 1, alternately displaying the currently selected torque wrench No. 1 and "T4".

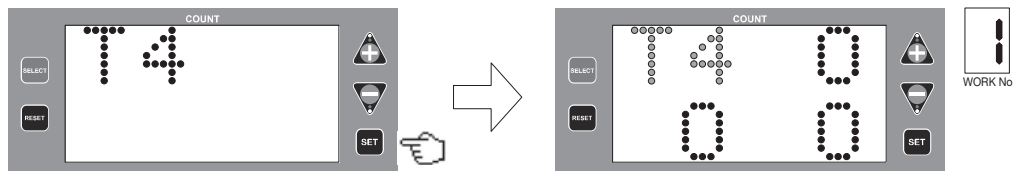

[Description of the setting data]
 Set the interval timer within a range of 0 to 60 seconds. This function is enabled only when the usage order setting is ON.
 For details, see page 14.
 Factory setting: 0 second

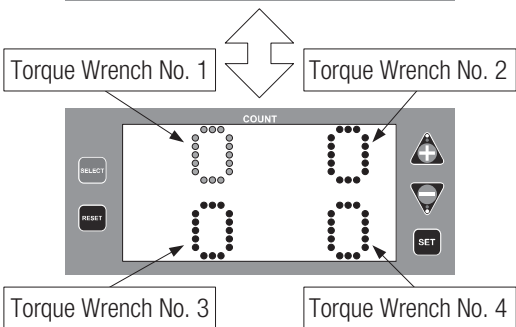

(2) Press the ▲ or ▼ key to set the time (seconds).

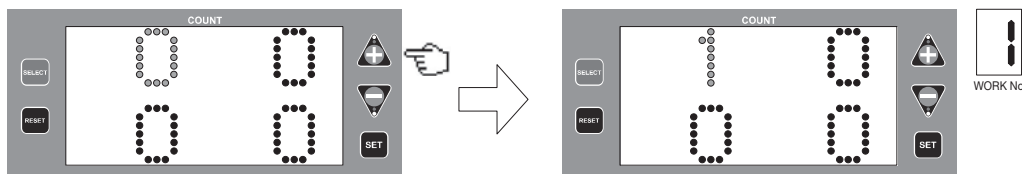

(3) Pressing the SELECT key to change the torque wrench No. from 1 to 2, 3 and 4, set the time (seconds) for each torque wrench No. in the same manner as mentioned above.

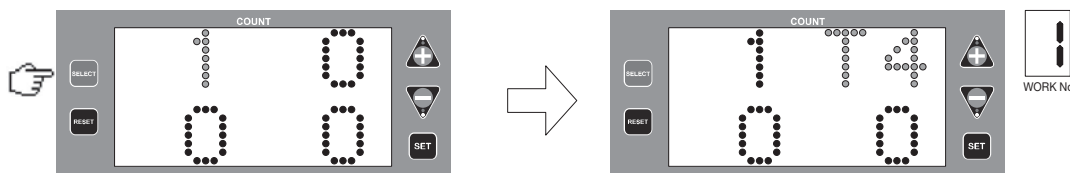

(4) Once you are finished with setting for each torque wrench No. of the work No. 1, press the SET key. The setting of each torque wrench is entered and control goes to the next work No. 2. Set the data for each work No. in the same manner.

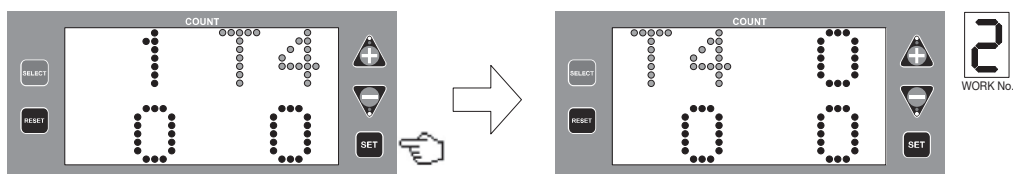

Once the setting of the work No. 8 is entered, the OK output pattern setting screen appears.

(5) To return to the setting item selection screen halfway setting, press the RESET switch.

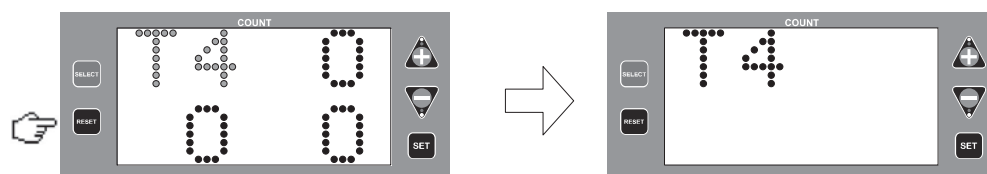

• OK output pattern setting

(1) Press the SET key. The OK output pattern setting for the work No. 1 appears and alternates with "OU".

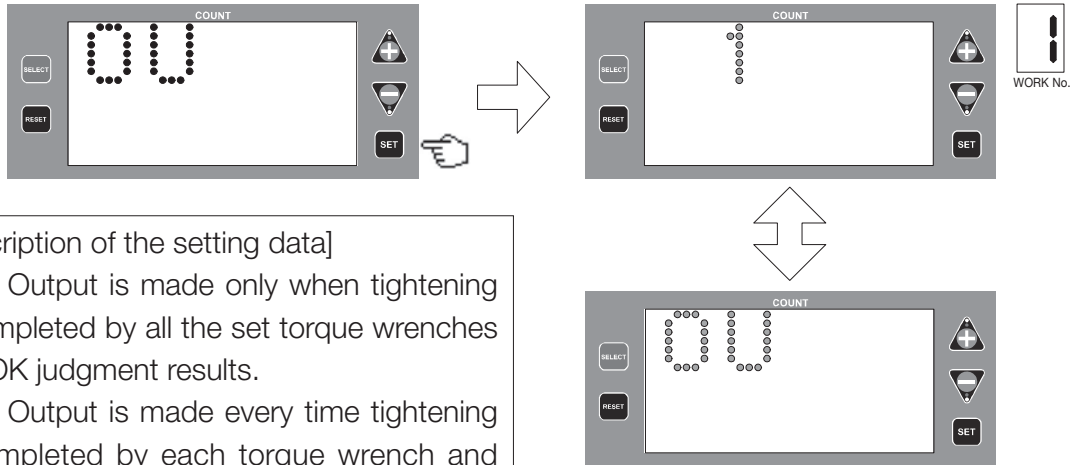

[Description of the setting data]
 OU1: Output is made only when tightening is completed by all the set torque wrenches and OK judgment results.
 OU2: Output is made every time tightening is completed by each torque wrench and OK judgment results.
 This function is enabled only when the usage order setting is ON.
 Factory setting: OU1

(2) Press the ▲ or ▼ key to select the OK output pattern.

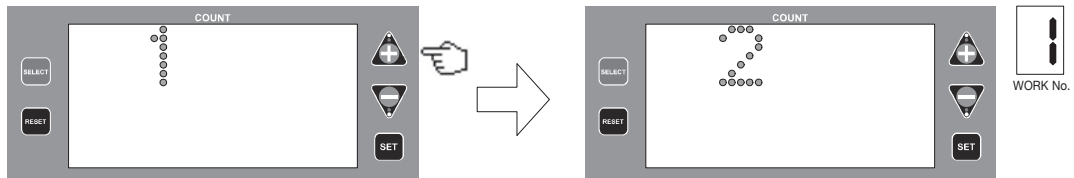

(3) Once selection is made, press the SET key. The setting is entered and control goes to the next work No. 2. Set the data for each work No. in the same manner.

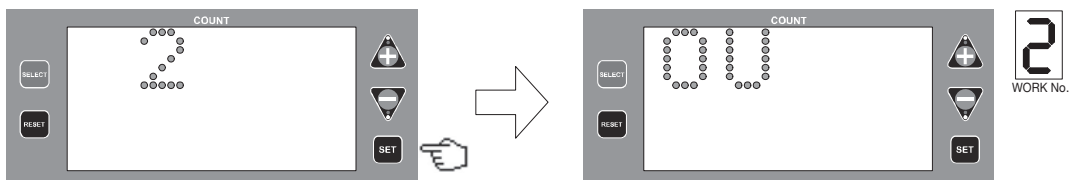

Once the setting of the work No. 8 is entered, the automatic reset timer 2 setting screen appears.

(4) To return to the setting item selection screen halfway setting, press the RESET switch.

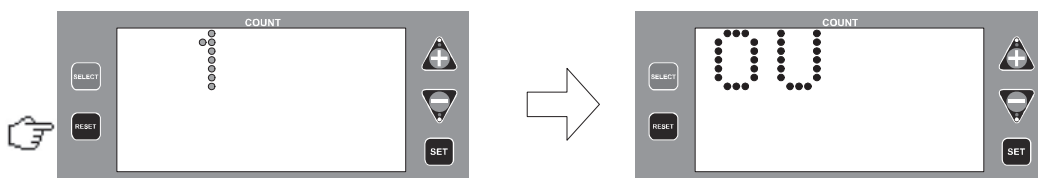

• Automatic reset timer 2 setting

(1) Press the SET key. The automatic reset timer setting appears for each torque wrench No. of the work No. 1, alternately displaying the currently selected torque wrench No. 1 and "T5".

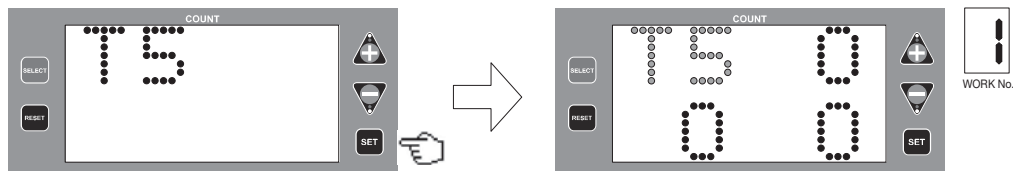

[Description of the setting data]
 Set the automatic reset timer 2 within a range of 0 to 60 seconds (in steps of 1 second).
 This function is enabled only when the usage order setting is ON and the OK output pattern setting is OU2.
 For details, see page 12.
 Factory setting: 0 second

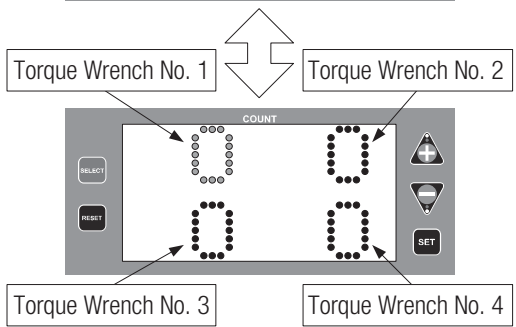

(2) Press the ▲ or ▼ key to set the time (seconds).

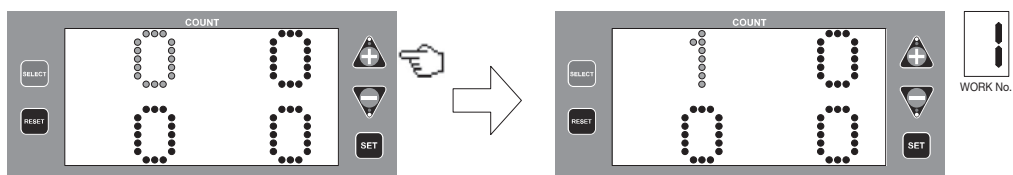

(3) Pressing the SELECT key to change the torque wrench No. from 1 to 2, 3 and 4, set the time (seconds) for each torque wrench No. in the same manner as mentioned above.

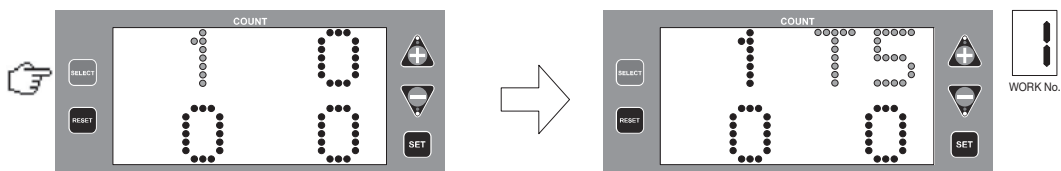

(4) Once you are finished with setting for each torque wrench No. of the work No. 1, press the SET key. The setting for each torque wrench is entered and control goes to the next work No. 2. Set the data for each work No. in the same manner.

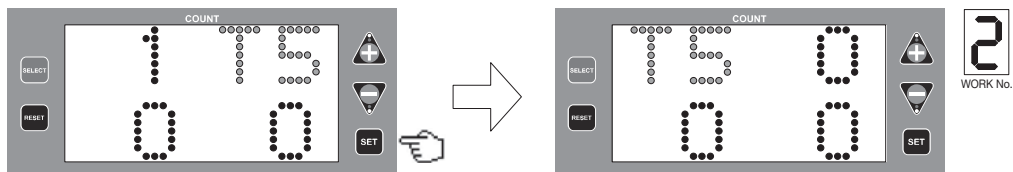

Once the setting of the work No. 8 is entered, the automatic judgment timer 2 setting screen appears.

(5) To return to the setting item selection screen halfway setting, press the RESET switch.

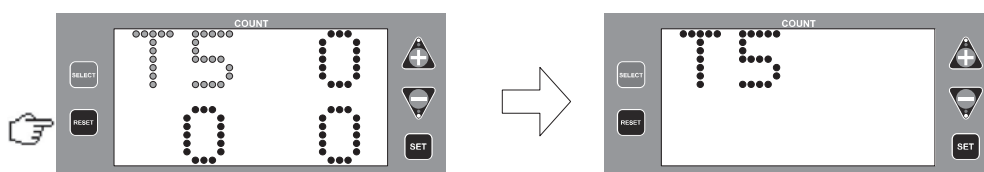

• Automatic judgment timer 2 setting

- (1) Press the SET key. Automatic judgment timer 2 setting appears for each torque wrench No. of the work No. 1, alternately displaying the currently selected torque wrench No. 1 and "T6".

[Description of the setting data]
Set the automatic judgment timer 2 within a range of 1 to 300 seconds (in steps of 1 second).
This function is enabled only when the judgment mode setting is JG2 or JG3, the usage order setting is ON, and the OK output pattern setting is OU2.
For details, see page 13.
Factory setting: 1 second

Torque Wrench No. 1

Torque Wrench No. 2

Torque Wrench No. 3

Torque Wrench No. 4

- (2) Press the ▲ or ▼ key to set the time (seconds).

WORK No. 1

- (3) Pressing the SELECT key to change the torque wrench No. from 1 to 2, 3 and 4, set the time (seconds) for each torque wrench No. in the same manner as mentioned above.

WORK No. 2

- (4) Once you are finished with setting for each torque wrench No. of the work No. 1, press the SET key. The setting for each torque wrench is entered and control goes to the next work No. 2. Set the data for each work No. in the same manner.

WORK No. 2

Once the setting of the work No. 8 is entered, "END" appears in the display section to end the setting procedure. Turn off the product and turn it on again to check its operations.

- (5) To return to the setting item selection screen halfway setting, press the RESET switch.

6-2. Setting Procedure by PC

(1) Pressing the ▼ key and the SET key, turn on the main body. “PCSET” appears in the display section.

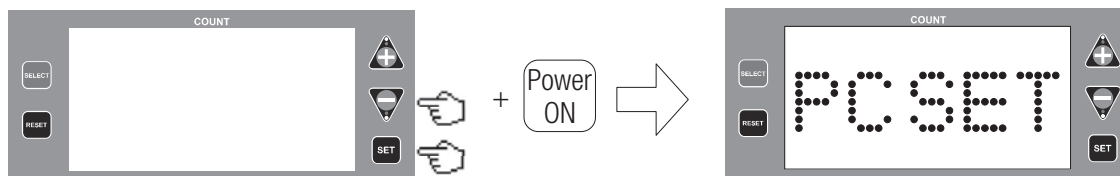

(2) Using an accessory USB cable (A-B type), connect the CNA-4mk3 to a PC where CNA-4mk3 parameter setting software and USB driver have been already installed.

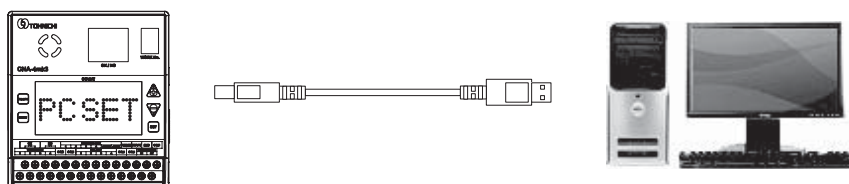

(3) Start up the PC's CNA-4mk3 parameter setting software.

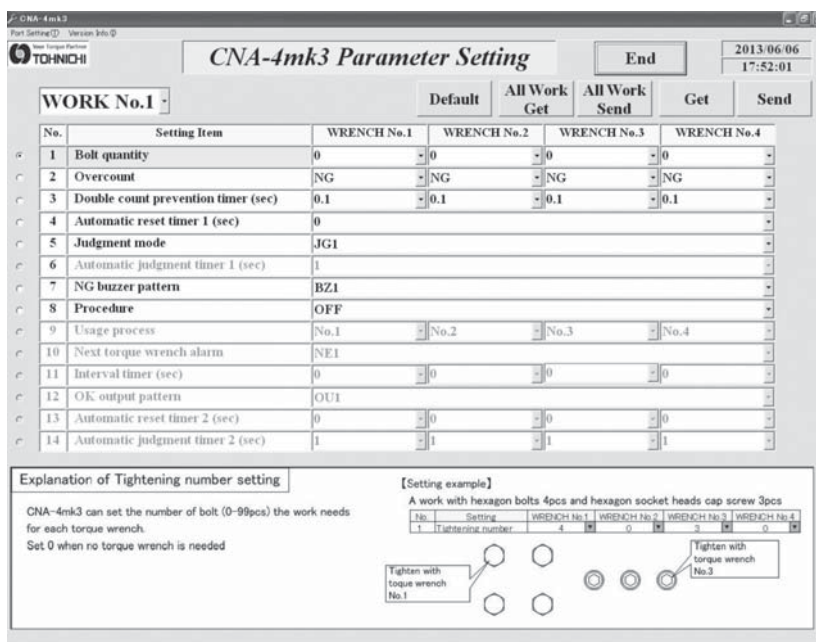

[Description of the setting data]

- Tightening number of bolts setting

Set the tightening number of bolts within a range of 0 to 99 pcs. Set 0 for the unused torque wrench.

(Factory setting: Torque wrench No. 1, 2, 3 and 4 = 1, 0, 0 and 0 pc.)

- Overcount setting

NG: NG judgment results when more bolts have been tightened than the set tightening

number of bolts. (This function is enabled only when the usage order setting is ON and entire tightening operation ends after preset judgment.)

OK: OK judgment results even if more bolts have been tightened than the set tightening number of bolts.

(Factory setting: NG)

- Double count prevention timer setting

Set the double count prevention timer within a range of 0.1 to 10.0 seconds (in steps of 0.1 second). For details, see page 12.

(Factory setting: 0.1 second)

- Automatic reset timer 1 setting

Set the automatic reset timer 1 within a range of 0 to 60 seconds (in steps of 1 second). For details, see page 12.

(Factory setting: 0 second)

- Judgment mode setting

JG1: Makes OK/NG judgment with preset judgment (count “0” for OK judgment) or END input.

JG2: Makes OK/NG judgment with preset judgment, END input or the automatic judgment timer.

JG3: Makes OK/NG judgment with the automatic judgment timer.

JG4: Makes OK/NG judgment with END input.

(Factory setting: JG1)

- Automatic judgment timer 1 setting

Set the automatic judgment timer 1 within a range of 1 to 300 seconds (in steps of 1 second).

This function is enabled only when the judgment mode setting is JG2 or JG3. For details, see page 13.

(Factory setting: 1 second)

- NG buzzer sound pattern setting

BZ1: Long beep

BZ2: Triple long beep

BZ3: Long beep followed by double short beep

BZ4: Long beep followed by triple short beep

For details, see page 13. (Factory setting: BZ1)

- Usage order setting

OFF: Select this in case of simultaneous tightening by multiple workers or when using torque

wrenches randomly with no usage order.

ON: Select this when using the torque wrenches according to the usage order.

For details, see page 14. (Factory setting: OFF)

- Usage order No. setting

Set the torque wrench usage order. This function is enabled only when the usage order setting is ON.

(Factory setting: Torque wrench No. 1, 2, 3 and 4 = 1, 2, 3 and 4)

- NEXT torque wrench alarm setting

NE1: When there is the next torque wrench, the OK lamp blinks and the buzzer sounds.

NE2: When there is the next torque wrench, the OK lamp blinks.

NE3: No alarm.

This function is enabled only when the usage order setting is ON. (Factory setting: NE1)

- Interval timer setting

Set the interval timer within a range of 0 to 60 seconds. This function is enabled only when the usage order setting is ON.

For details, see page 14. (Factory setting: 0 second)

- OK output pattern setting

OU1: Output is made only when tightening is completed by all the set torque wrenches and OK judgment results.

OU2: Output is made every time tightening is completed by each torque wrench and OK judgment results.

This function is enabled only when the usage order setting is ON. (Factory setting: OU1)

- Automatic reset timer 2 setting

Set the automatic reset timer 2 within a range of 0 to 60 seconds (in steps of 1 second). This function is enabled only when the usage order setting is ON and the OK output pattern setting is OU2.

For details, see page 12. (Factory setting: 0 second)

- Automatic judgment timer 2 setting

Set the automatic judgment timer 2 within a range of 1 to 300 seconds (in steps of 1 second). This function is enabled only when the judgment mode setting is JG2 or JG3, the usage order setting is ON, and the OK output pattern setting is OU2.

For details, see page 13. (Factory setting: 1 second)

(4) Select the work No. you want to alter the setting in the combo box and click on the “Get” button. The current setting values of the CNA-4mk3 are received and displayed for each item.

Clicking on the “All Work Get” button receives the current setting values of the work Nos. 1 to 8 as well as those of the work No. selected in the combo box.

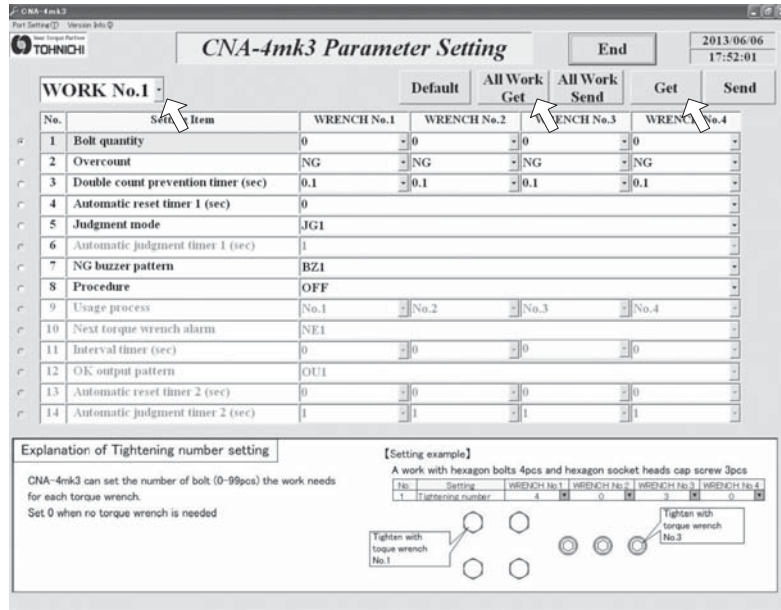

(5) Click on the option button for the setting item you want to alter. The functional description of the selected setting item appears at the bottom of the screen. See the description to alter the setting.

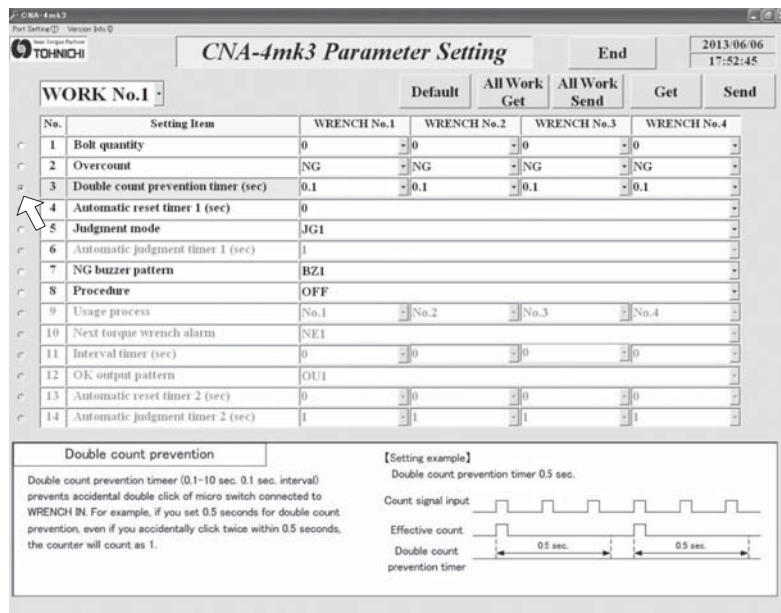

* To initialize the display information of the setting, click on the “Default” button.
(The setting of the CNA-4mk3 is not altered.)

(6) Once you are finished with altering each item, click on the “Send” button. The currently displayed setting values of the selected work No. are sent to the CNA-4mk3 to rewrite the setting of the CNA-4mk3.

Clicking on the “All Work Send” button sends the setting values of the work Nos. 1 to 8 as well as those of the work No. selected in the combo box.

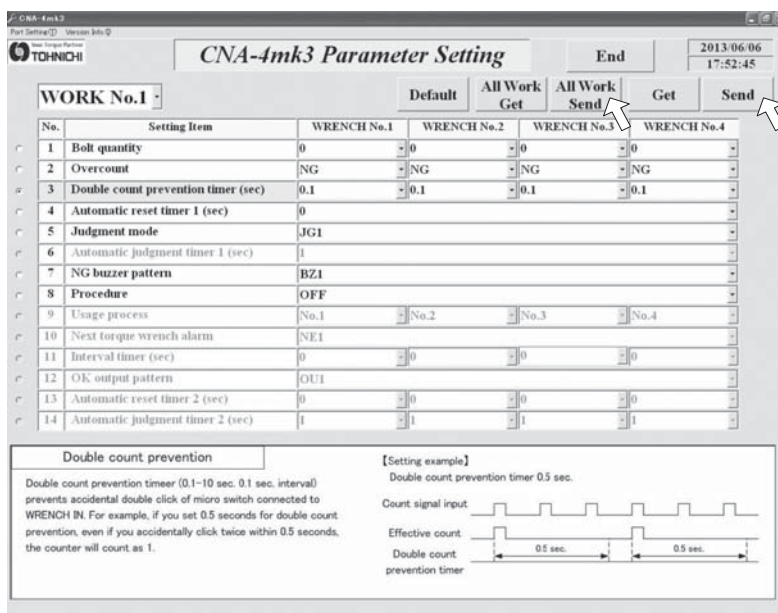

(7) Set the data for each work No. in the same manner. Once setting is completed, disconnect the USB cable, turn off the CNA-4mk3, and turn it on again to check operations.

7 Usage Example

Usage example A

- Torque wrench 1pc
- Overcount NG
- Preset judgment
- No automatic reset

[Parameter setting]

No.	Setting item	WRENCH No.1	WRENCH No.2	WRENCH No.3	WRENCH No.4
1	Tightening number of bolts	3	0	0	0
2	Overcount	NG	NG	NG	NG
3	Double count prevention timer	0.1	0.1	0.1	0.1
4	Automatic reset timer 1	0			
5	Judgment mode	JG1			
6	Automatic judgment timer 1	1			
7	NG buzzer sound pattern	BZ1			
8	Usage order	OFF			
9	Usage order No.	No.1	No.2	No.3	No.4
10	Next torque wrench alarm	NE1			
11	Interval timer	0	0	0	0
12	OK output pattern	OU1			
13	Automatic reset timer 2	0	0	0	0
14	Automatic judgment timer 2	1	1	1	1

[Timing chart]

(1) Normal

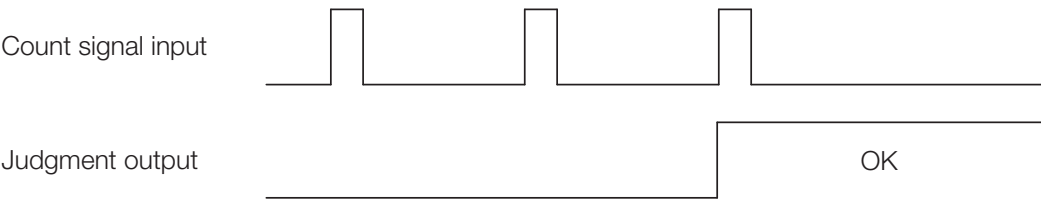

(2) Overcount

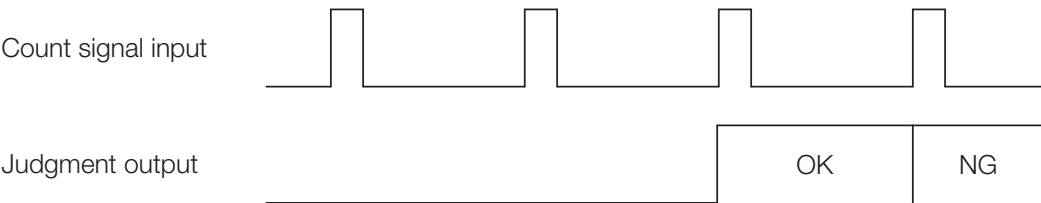

Usage example B

- Torque wrench 1pc
- Judgment by END input
- No automatic reset (with RESET input)

[Parameter setting]

No.	Setting item	WRENCH No.1	WRENCH No.2	WRENCH No.3	WRENCH No.4
1	Tightening number of bolts	3	0	0	0
2	Overcount	NG	NG	NG	NG
3	Double count prevention timer	0.1	0.1	0.1	0.1
4	Automatic reset timer 1	0			
5	Judgment mode	JG4			
6	Automatic judgment timer 1	1			
7	NG buzzer sound pattern	BZ1			
8	Usage order	OFF			
9	Usage order No.	No.1	No.2	No.3	No.4
10	Next torque wrench alarm	NE1			
11	Interval timer	0	0	0	0
12	OK output pattern	OU1			
13	Automatic reset timer 2	0	0	0	0
14	Automatic judgment timer 2	1	1	1	1

[Timing chart]

(1) Judgment OK

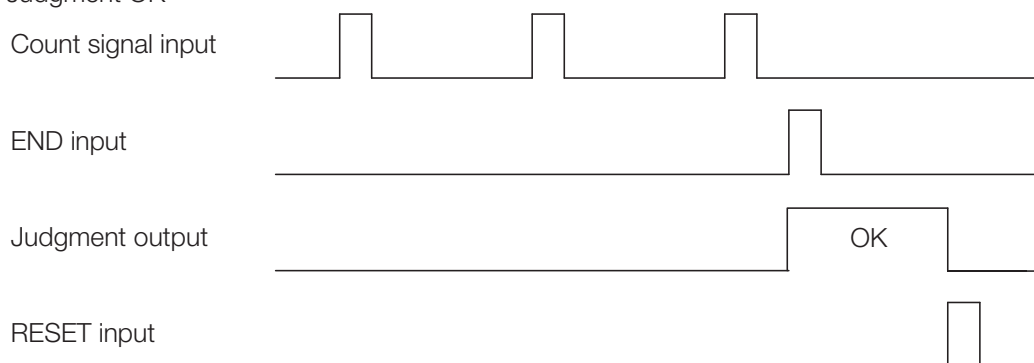

(2) Judgment NG→OK

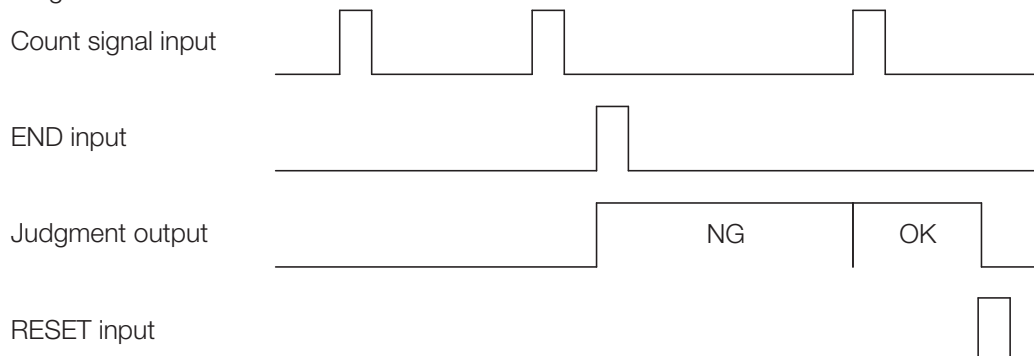

Usage example C

- Torque wrench 1pc
- Automatic judgment
- Automatic reset

[Parameter setting]

No.	Setting item	WRENCH No.1	WRENCH No.2	WRENCH No.3	WRENCH No.4
1	Tightening number of bolts	3	0	0	0
2	Overcount	NG	NG	NG	NG
3	Double count prevention timer	0.1	0.1	0.1	0.1
4	Automatic reset timer 1	2			
5	Judgment mode	JG3			
6	Automatic judgment timer 1	6			
7	NG buzzer sound pattern	BZ1			
8	Usage order	OFF			
9	Usage order No.	No.1	No.2	No.3	No.4
10	Next torque wrench alarm	NE1			
11	Interval timer	0	0	0	0
12	OK output pattern	OU1			
13	Automatic reset timer 2	0	0	0	0
14	Automatic judgment timer 2	0	0	0	0

[Timing chart]

(1) Judgment OK

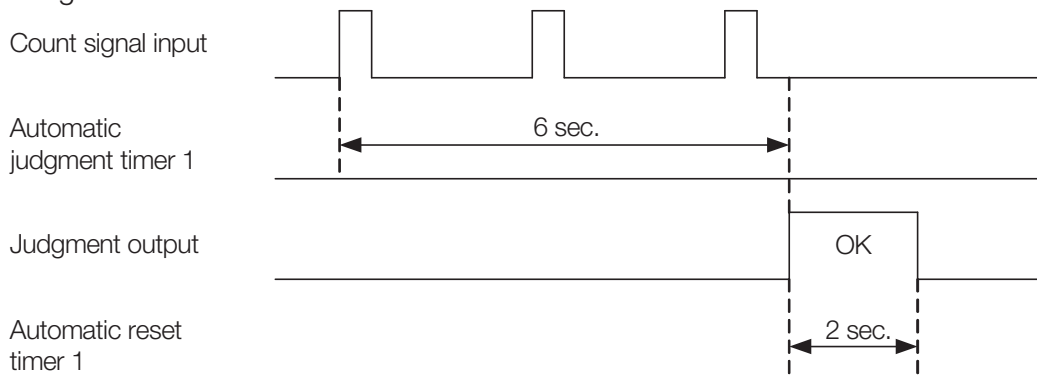

(2) Judgment NG→OK

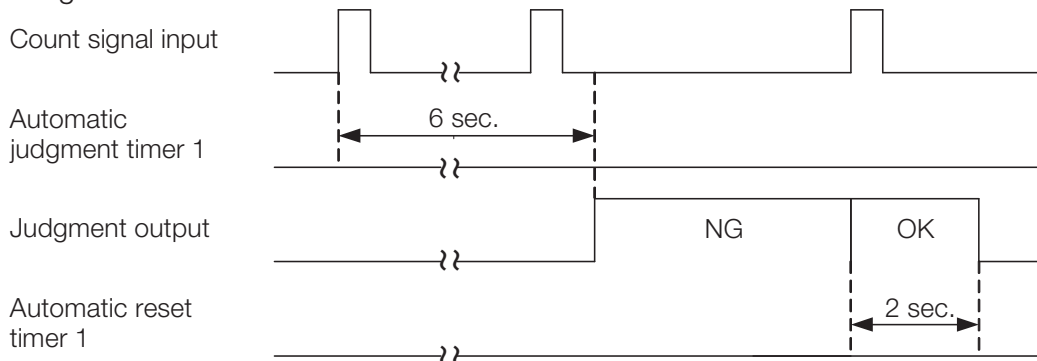

Usage example D

- Torque wrench 1pc
- Automatic judgment
- Automatic reset
- START input

[Parameter setting]

No.	Setting item	WRENCH No.1	WRENCH No.2	WRENCH No.3	WRENCH No.4
1	Tightening number of bolts	3	0	0	0
2	Overcount	NG	NG	NG	NG
3	Double count prevention timer	0.1	0.1	0.1	0.1
4	Automatic reset timer 1	2			
5	Judgment mode	JG3			
6	Automatic judgment timer 1	6			
7	NG buzzer sound pattern	BZ1			
8	Usage order	OFF			
9	Usage order No.	No.1	No.2	No.3	No.4
10	Next torque wrench alarm	NE1			
11	Interval timer	0	0	0	0
12	OK output pattern	OU1			
13	Automatic reset timer 2	0	0	0	0
14	Automatic judgment timer 2	0	0	0	0

[Timing chart]

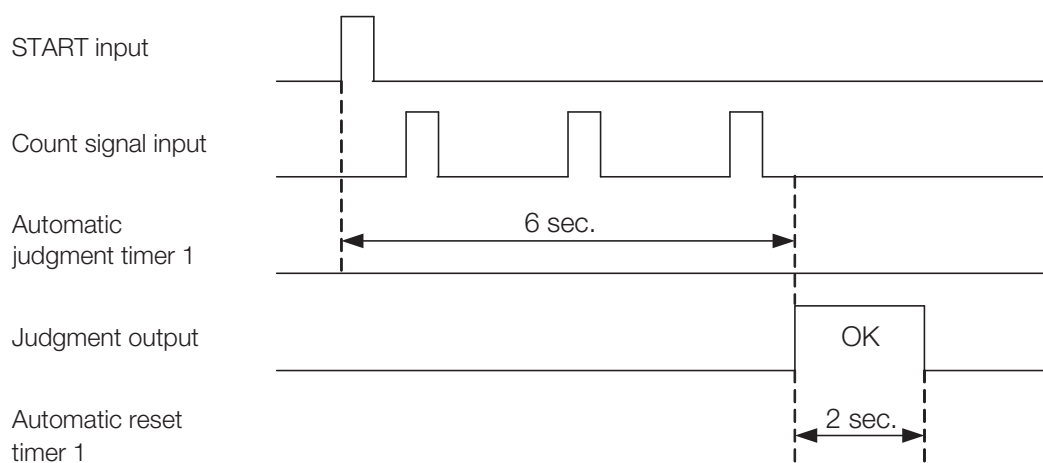

Usage example E

- Torque wrench 1pc
- Preset judgment + automatic judgment
- Automatic reset
- Usage order ON
- Interval timer

[Parameter setting]

No.	Setting item	WRENCH No.1	WRENCH No.2	WRENCH No.3	WRENCH No.4
1	Tightening number of bolts	3	0	0	0
2	Overcount	NG	NG	NG	NG
3	Double count prevention timer	0.1	0.1	0.1	0.1
4	Automatic reset timer 1	2			
5	Judgment mode	JG2			
6	Automatic judgment timer 1	6			
7	NG buzzer sound pattern	BZ1			
8	Usage order	ON			
9	Usage order No.	No.1	No.2	No.3	No.4
10	Next torque wrench alarm	NE1			
11	Interval timer	2	0	0	0
12	OK output pattern	OU1			
13	Automatic reset timer 2	0	0	0	0
14	Automatic judgment timer 2	0	0	0	0

[Timing chart]

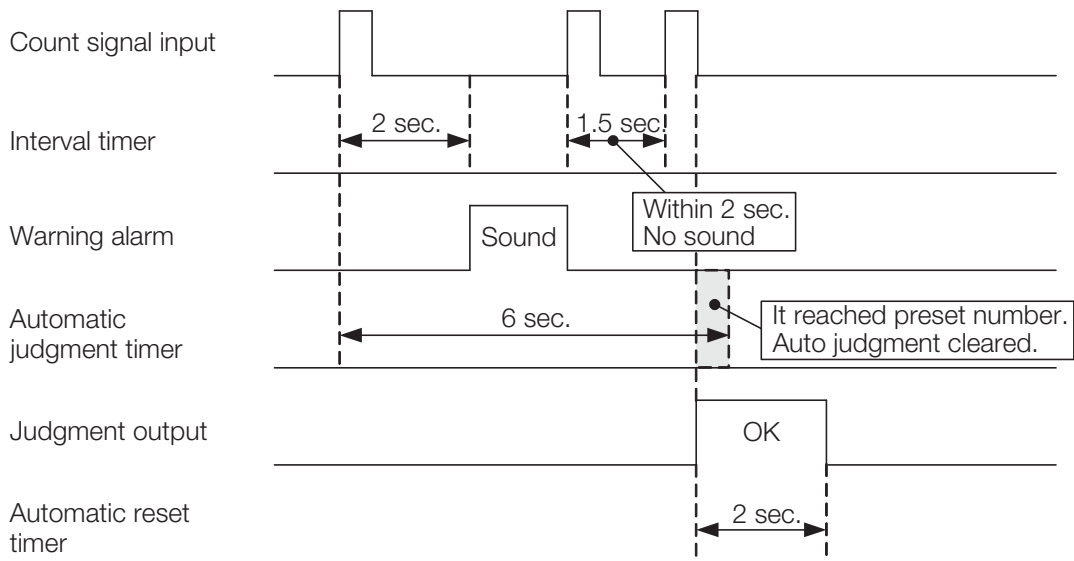

Usage example F

- Torque wrench 1pc
- Preset judgment
- Automatic reset
- WORK SENSOR input

[Parameter setting]

No.	Setting item	WRENCH No.1	WRENCH No.2	WRENCH No.3	WRENCH No.4
1	Tightening number of bolts	3	0	0	0
2	Overcount	NG	NG	NG	NG
3	Double count prevention timer	0.1	0.1	0.1	0.1
4	Automatic reset timer 1	2			
5	Judgment mode	JG1			
6	Automatic judgment timer 1	1			
7	NG buzzer sound pattern	BZ1			
8	Usage order	OFF			
9	Usage order No.	No.1	No.2	No.3	No.4
10	Next torque wrench alarm	NE1			
11	Interval timer	0	0	0	0
12	OK output pattern	OU1			
13	Automatic reset timer 2	0	0	0	0
14	Automatic judgment timer 2	1	1	1	1

[Timing chart]

(1) Judgment OK

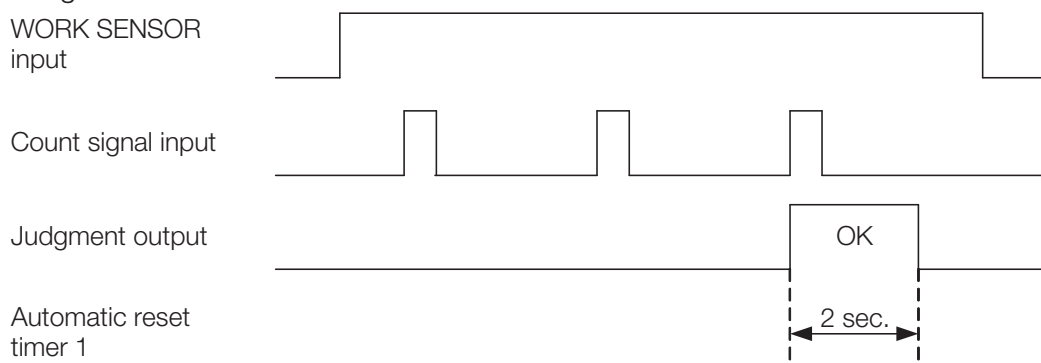

(2) Judgment NG

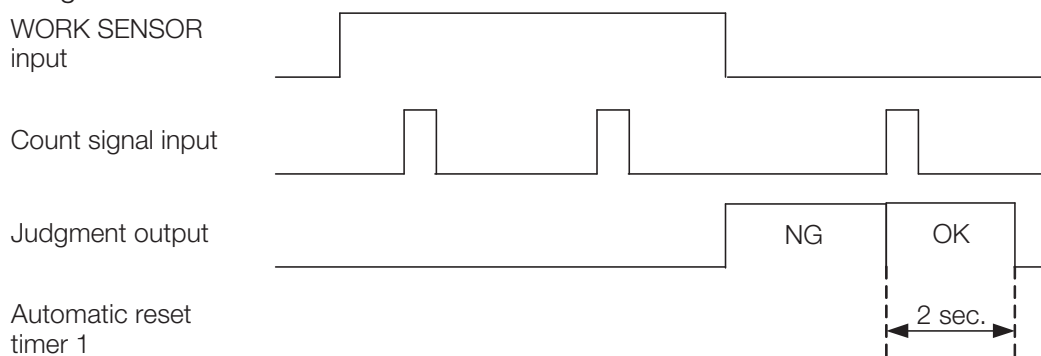

Usage example G

- Torque wrench 2pcs
- Preset judgment
- Automatic reset
- Usage order OFF

[Parameter setting]

No.	Setting item	WRENCH No.1	WRENCH No.2	WRENCH No.3	WRENCH No.4
1	Tightening number of bolts	3	2	0	0
2	Overcount	NG	NG	NG	NG
3	Double count prevention timer	0.1	0.1	0.1	0.1
4	Automatic reset timer 1	2			
5	Judgment mode	JG1			
6	Automatic judgment timer 1	0			
7	NG buzzer sound pattern	BZ1			
8	Usage order	OFF			
9	Usage order No.	No.1	No.2	No.3	No.4
10	Next torque wrench alarm	NE1			
11	Interval timer	0	0	0	0
12	OK output pattern	OU1			
13	Automatic reset timer 2	0	0	0	0
14	Automatic judgment timer 2	0	0	0	0

[Timing chart]

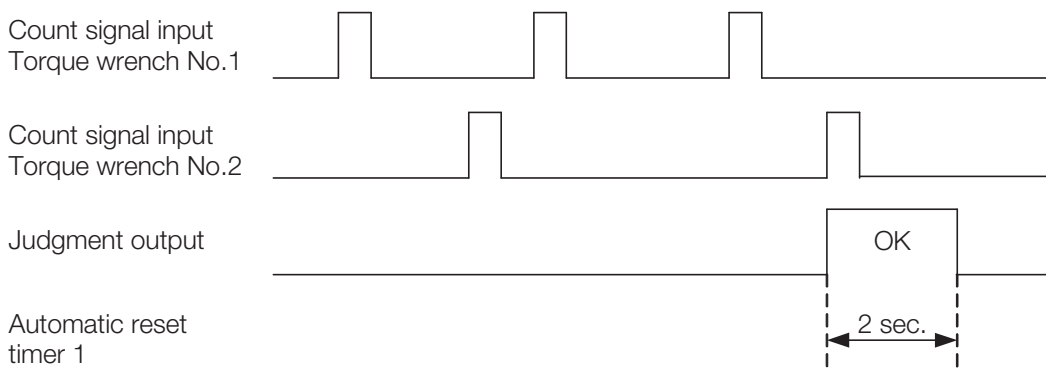

Usage example H

- Torque wrench 3pcs
- Preset judgment + Automatic judgment
- Automatic reset
- Usage order ON
- NEXT torque wrench alarm
- OK judgment output by each tightening of every torque wrench

[Parameter setting]

No.	Setting item	WRENCH No.1	WRENCH No.2	WRENCH No.3	WRENCH No.4
1	Tightening number of bolts	3	2	3	0
2	Overcount	NG	NG	NG	NG
3	Double count prevention timer	0.1	0.1	0.1	0.1
4	Automatic reset timer 1	0			
5	Judgment mode	JG2			
6	Automatic judgment timer 1	1			
7	NG buzzer sound pattern	BZ1			
8	Usage order	ON			
9	Usage order No.	No.1	No.2	No.3	No.4
10	Next torque wrench alarm	NE1			
11	Interval timer	0	0	0	0
12	OK output pattern	OU2			
13	Automatic reset timer 2	2	2	4	0
14	Automatic judgment timer 2	6	4	6	0

[Timing chart]

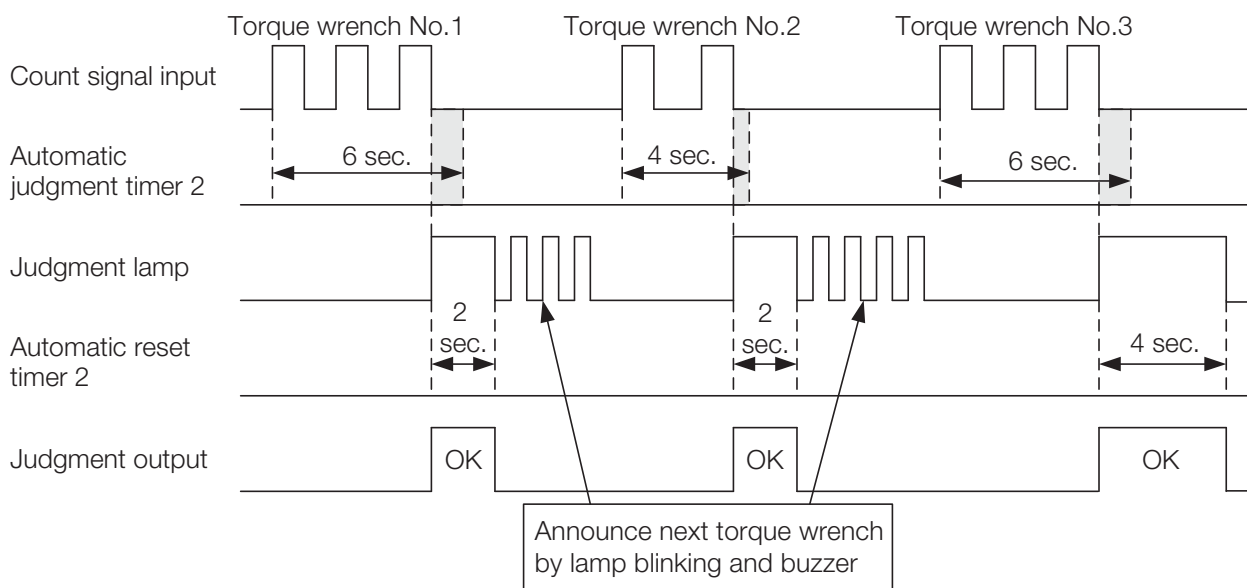

8 Optional Accessories

- Loud buzzer (Type: CNA-BZ)

The use of this buzzer allows you to hear a buzzer sound even in a very noisy work environment.
[Buzzer replacement procedure]

* Be sure to disconnect the AC adapter of the product from a plug socket before replacing the buzzer.

Tools used

- Phillips screwdriver
- Torque screwdriver (for example, RTD120CN, #2 (H-2) Plus bit)

(1) Using the Phillips screwdriver, remove four M3 countersunk screws from the back of the case.

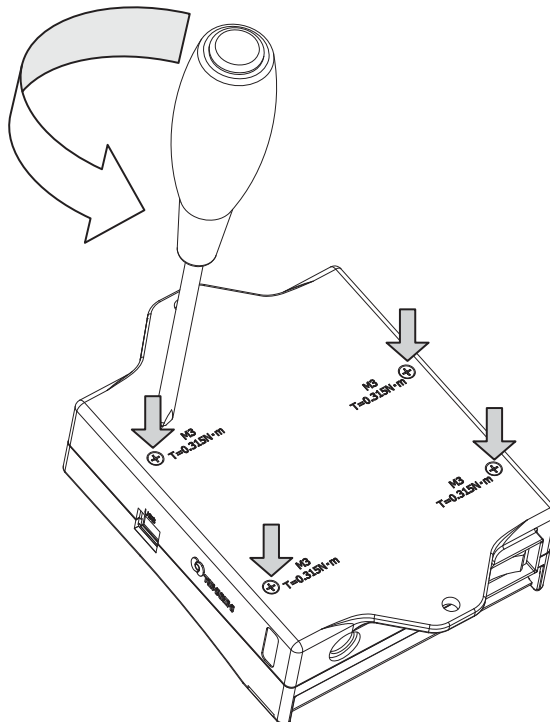

(2) Remove a substrate from the case and detach a connector for a standard buzzer from the substrate.

(3) Remove two M3 pan head cap screws used for fixing the standard buzzer.

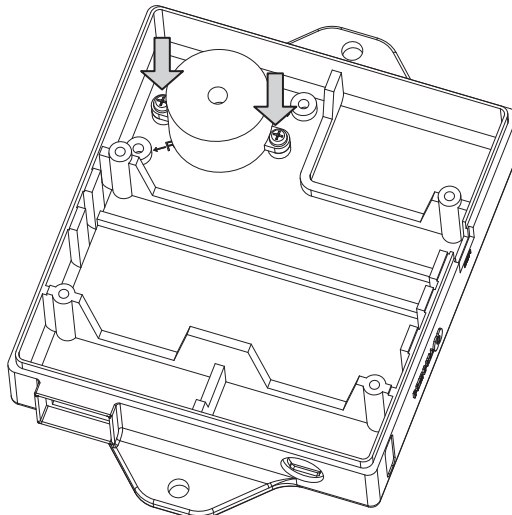

- (4) Using two M4 pan head cap screws coming with the loud buzzer, fix the loud buzzer to the part marked "For Optional Buzzer". (Tightening torque $T = 0.76 \text{ N}\cdot\text{m}$)

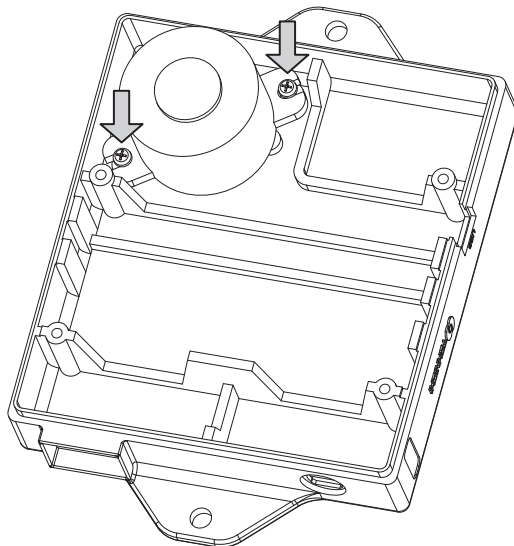

- (5) Insert a connector for the loud buzzer into the substrate.
 (6) Assemble the substrate to the case carefully not to catch the wiring, align the top and bottom portions of the case with each other, and tighten four M3 countersunk screws. (Tightening torque $T = 0.315 \text{ N}\cdot\text{m}$)

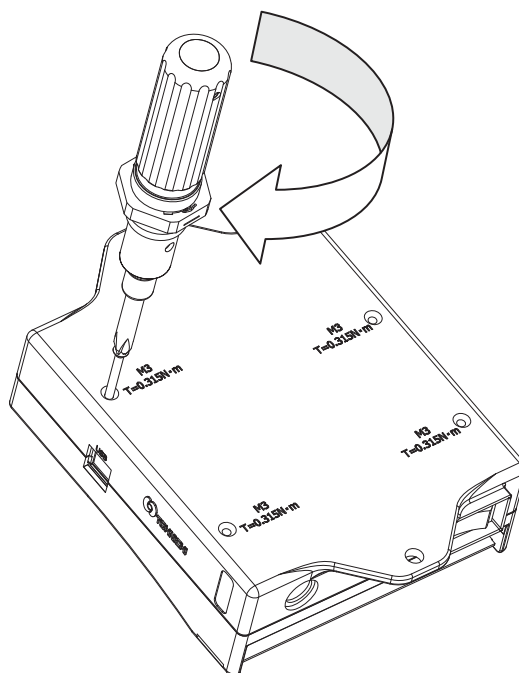

- (7) Finally, connect the AC adapter to the plug socket and turn on the power to check operations.

9 Troubleshooting

Before determining that the product is faulty, check the items listed in the following table. Since the product is provided with the self check mode, use it to check each display function and I/O function. If a faulty phenomenon still persists, contact your nearest distributor or our sales department.

Phenomenon	Cause	Remedy
The power is not turned on.	Disconnected AC adapter	Insert the AC adapter fully into the connector.
The counter display is not turned off.	Not energized	Turn on the power switch, if turned on.
Does not count down.	Contact failure of wiring	Crimp an electric wire firmly to a crimping terminal. Attach a crimping terminal firmly to the terminal block with a specified torque.
	Snapped wiring	Replace the wiring.
	Wiring error	See pages 7 and 8 to rewire.
	Limit switch operational failure of the LS torque wrench	Inspect the LS torque wrench.
Counts down on and off.	Improper setting time of the double count prevention timer	Re-set the double count prevention timer.
The input terminals do not function.	Contact failure of wiring	Crimp an electric wire firmly to a crimping terminal. Attach a crimping terminal firmly to the terminal block with a specified torque.
	Snapped wiring	Replace the wiring.
	Wiring error	See pages 7 and 8 to rewire.
The END input terminal does not function.	Judgment mode setting JG3	To enable END input, set the judgment mode to JG1 or JG2.
Cannot make automatic judgment.	Judgment mode setting JG1 or JG4	To enable automatic judgment, set the judgment mode to JG2 or JG3.
NG judgment results before tightening all the set tightening number of bolts.	Improper setting time of automatic judgment timers 1 and 2	Re-set the automatic judgment timers 1 and 2.
"Err8" appears.	Memory error	Setting error. Re-setting is required. If the phenomenon still persists, ask for repair.

9-1. Self Check Mode

(1) Pressing the SELECT key, turn on the main body. "SELF CHECK" appears in the display section.

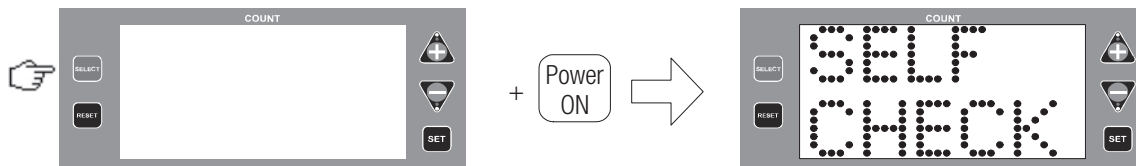

(2) Hold down the SET key for 2 seconds to start the self check mode.

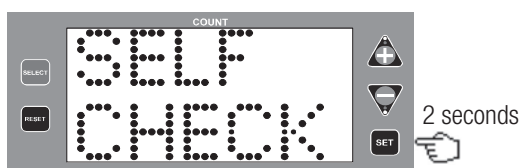

(3) Checking the count display section

All the dot-matrix LEDs are turned on. Check that there is no missing dot.

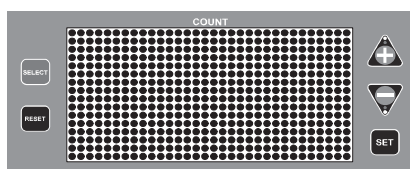

(4) Checking the work No. display section

All the 7-segment LED is turned on ("8"). Check that there is no missing segment.



(5) Checking the OK/NG judgment lamps and output terminals

Interlocked with the blue and red OK/NG judgment lamps, the OK/NG judgment output terminals are turned on. Connect a LED lamp, etc. to check respectively.

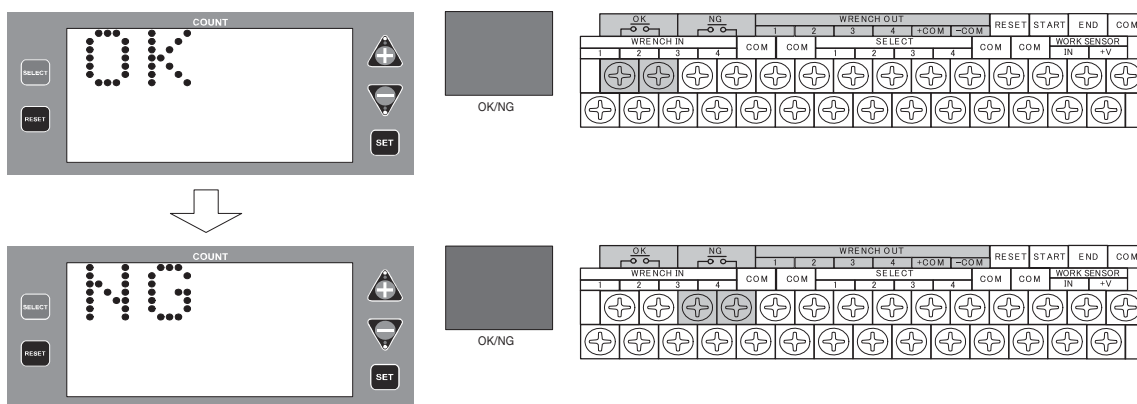

(6) Checking the WRENCH OUT output terminals

All the WRENCH OUT output terminals are turned on. Connect a LED lamp, etc. to check output.

(7) Checking the SELECT key

Press the SELECT key. If it functions properly, proceed to check the next key.

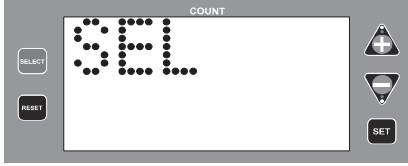

(8) Checking the RESET key

Press the RESET key. If it functions properly, proceed to check the next key.

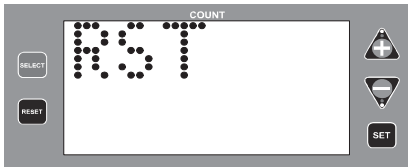

(9) Checking the ▲ key

Press the ▲ key. If it functions properly, proceed to check the next key.

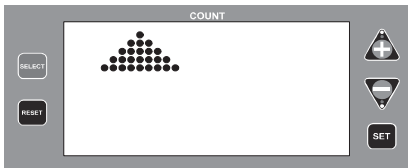

(10) Checking the ▼ key

Press the ▼ key. If it functions properly, proceed to check the next key.

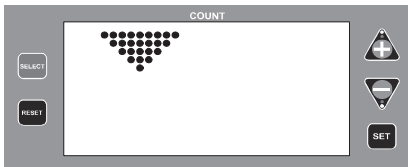

(11) Checking the SET key

Press the SET key. If it functions properly, proceed to check the next key.

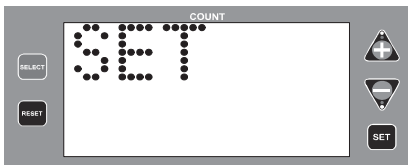

(12) Checking the WRENCH IN input terminals

Short-circuit between the WRENCH IN input terminals 1 to 4 and COM terminal in the order.

If they function properly, proceed to check the next input terminals.

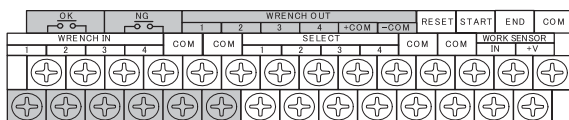
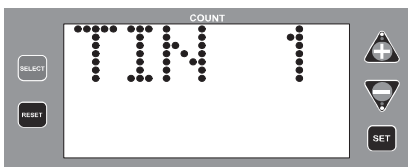

(13) Checking the SELECT input terminals

Short-circuit between the SELECT input terminals 1 to 4 and COM terminal (pulse input of 0.1 second or more). If they function properly, proceed to check the next input terminal.

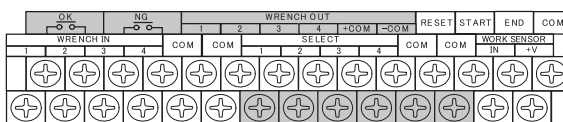
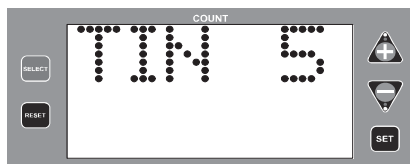

(14) Checking the RESET input terminal

Short-circuit between the RESET input terminal and COM terminal (pulse input of 0.1 second or more). If it functions properly, proceed to check the next input terminal.

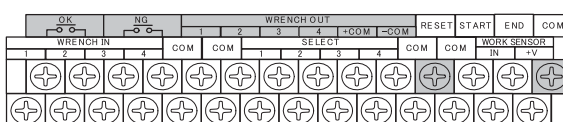
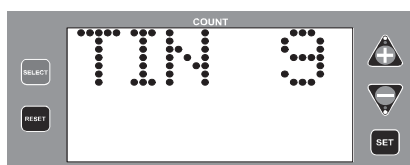

(15) Checking the START input terminal

Short-circuit between the START input terminal and COM terminal (pulse input of 0.1 second or more). If it functions properly, proceed to check the next input terminal.

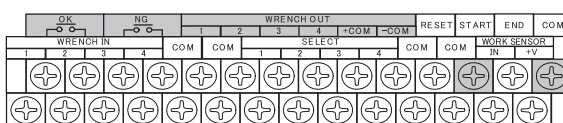
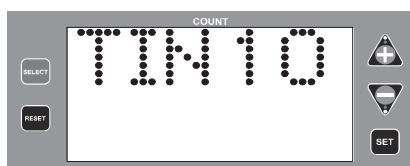

(16) Checking the END input terminal

Short-circuit between the END input terminal and COM terminal (pulse input of 0.1 second or more). If it functions properly, proceed to check the next input terminal.

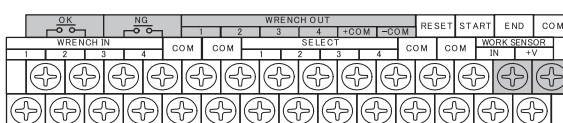
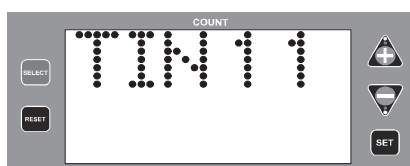

(17) Checking the WORK SENSOR input terminal

Input the signal of the proximity sensor, etc. to the WORK SENSOR input terminal. If it function properly, "END" appears in the display section, ending the self check mode. Turn off the product.

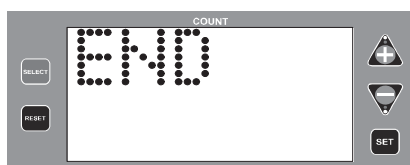
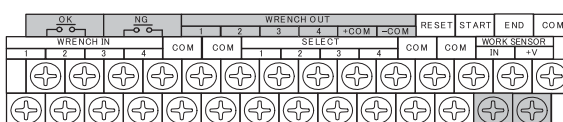
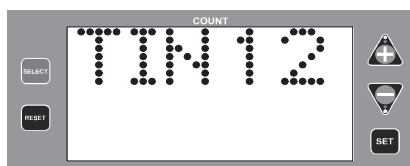

10 Specifications

Type	CNA-4mk3
Count display	16 x 32 dot-matrix LEDs
OK/NG judgment display	30 x 25 square display lamp (commonly used for OK/NG) OK: Blue lamp turned on NG: Red lamp blinking + buzzer sound (4 patterns)
Work No. selection display	1-digit 7-segment LED
Count input	Contact input x 4
Max. tightening number of bolts	99 counts
Max. number of works	8 sets
OK/NG judgment setting	Preset judgment End input judgment Automatic judgment (0 to 300 seconds in steps of 1 second)
Output function	OK/NG output (Relay contact output rating: 30 V DC, 1 A, 125 V AC, 0.3 A) Torque wrench selection signal output (Open collector output rating: 100 mA)
Input function	SELECT input x 4 START input END input RESET input WORK SENSOR input
Timer function setting	Double count prevention timer (0 to 10 seconds in steps of 0.1 second) Automatic reset timer (0 to 60 seconds in steps of 1 second) Interval warning timer (0 to 99 seconds in steps of 1 second)
Communication function	USB
Buzzer expansion function	Loud buzzer attachable as an option.
Setting method	Special-purpose application software (USB communication), key operation
Working temperature range	0 to 40°C, 85%RH or less (no dew condensation allowed)
Power supply, Power consumption	100 to 240 V AC, 50/60 Hz, below 10 W
Outer dimensions (mm)	121 (W) x 175 (D) x 44.4 (H)
Weight	Approx. 400 g

11 Dimensions

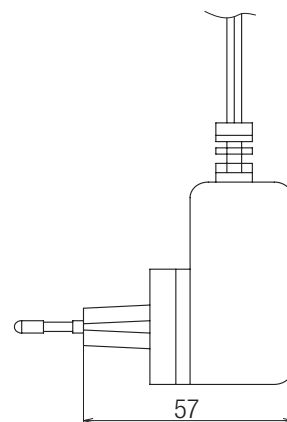
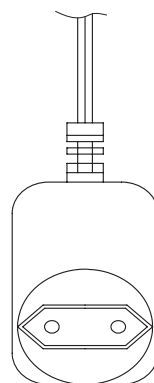
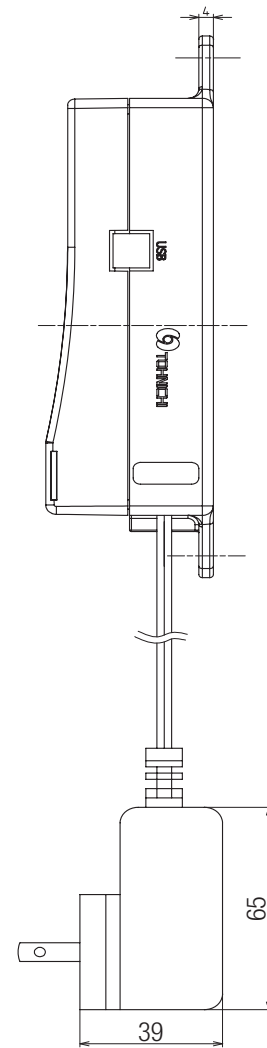
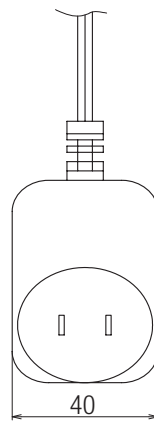
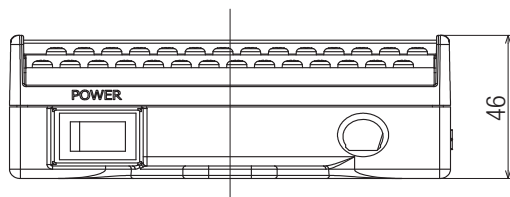
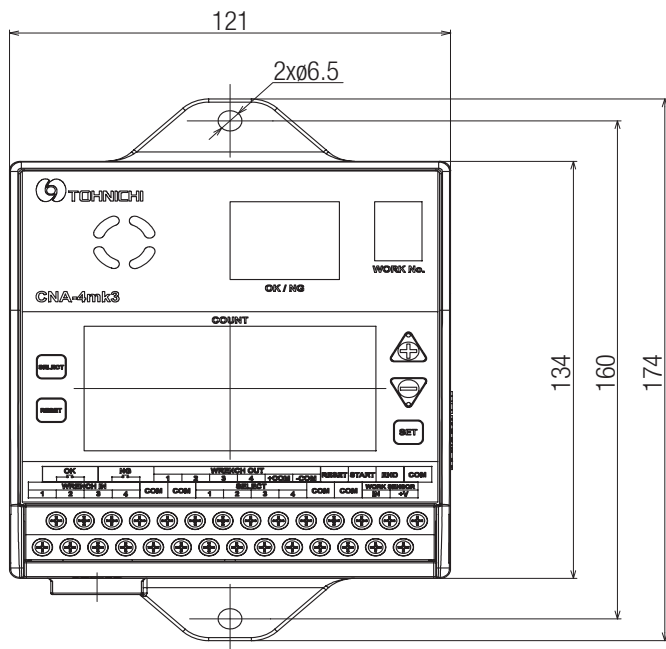

Designs and specifications are subject to change without notice.



■ **TOHNICHI MFG. CO., LTD.**

TEL: +81-(0)3-3762-2455 FAX: +81-(0)3-3761-3852
2-12, Omori-kita, 2-Chome Ota-ku, Tokyo 143-0016, JAPAN
E-mail: overseas@tohnichi.co.jp
Website: <http://tohnichi.jp>

■ **N. V. TOHNICHI EUROPE S. A.**

TEL: +32-(0)16-606661 FAX: +32-(0)16-606675
Industrieweg 27 Boortmeerbeek, B-3190 Belgium
E-mail: tohnichi-europe@online.be
Website: <http://www.tohnichi.be>

■ **TOHNICHI AMERICA CORP.**

TEL: +1-(0)847-947-8560 FAX: +1-(0)847-947-8572
1303 Barclay Blvd. Buffalo Grove, IL 60089 U. S. A.
E-mail: inquire@tohnichi.com
Website: <http://tohnichi.com>

■ **TOHNICHI AMERICA CORP. - Atlanta Office**

TEL: +1-(0)678-423-5777 FAX: +1-(0)678-423-1333
4046 Hwy. 154 Suite 103 Newnan, GA 30265

■ **TOHNICHI SHANGHAI MFG. CO., LTD.**

东仁扭矩仪器(上海)有限公司
TEL: +86-(021)3407-4008 FAX: +86-(021)3407-4135
Rm. 5 No. 99 Nong1919. Du Hui Road.
Minhang. Shanghai. P.R. China